

G.C.N.: **47-116-83** (24 kW)

G.C.N.: **47-116-84** (30 kW)

G.C.N.: **41-116-47** (24 kW)

G.C.N.: **41-116-48** (30 kW)

 **ARISTON**

# E-COMBI ONE E-SYSTEM ONE

## INSTALLATION AND SERVICING INSTRUCTIONS

### CONDENSING WALL-HUNG GAS BOILER

Country of Destination: GB/IE

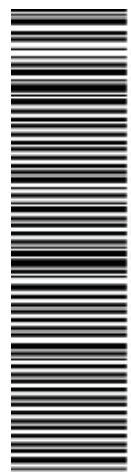

**UK  
CA**

**kiwa**  
approved  
product



UK WATER SUPPLY  
REGULATIONS



HOT WATER | HEATING | RENEWABLES

**CE**

## INDEX

<b>Overview</b> .....	3	<b>Commissioning</b> .....	31
General Information .....	4	Initial Preparation.....	31
Advice for the Installer.....	4	Electricity Supply .....	31
Data Plate Symbols.....	4	Filling the Heating System .....	31
Safety Regulations .....	5	Filling of the DHW System.....	31
UKCA Labelling.....	6	Gas Supply .....	31
CE Labelling .....	6	Water Treatment.....	31
<b>Product description</b> .....	7	First Igniton Operation.....	32
Control Panel .....	7	Ignition procedure.....	33
Display.....	8	Test Function and Combustion Analysis .....	34
Overall View.....	9	AUTO Function.....	36
Overall Dimension .....	10	<b>Boiler Protection Devices</b> .....	37
Minimum Clearances .....	10	Boiler Protection Devices.....	37
<b>Installation</b> .....	11	Table summarising error codes.....	37
Reference Standards .....	11	Anti-Frost Device .....	38
Installing the Boiler.....	14	<b>Settings - Adjustment - Problem Identification Menus</b>	
Gas Connection.....	15	Accessing the Menus .....	39
Water Connection .....	15	<b>Maintenance</b>	
Instructions for Opening the Casing and Performing an		General Comments .....	46
Internal Inspection.....	15	Operational Test.....	46
Underfloor heating .....	16	Draining procedures.....	46
Water circuit diagram.....	17	Cleaning the primary exchanger .....	46
Connecting the Flue .....	18	Cleaning the trap .....	46
Fitting the Coaxial Flue (Ø 60/100 Horizontal) .....	19	<b>Maintenance Guide</b>	
Fitting the 5" Flue (Ø 80/125 Horizontal / Vertical).....	20	General Access .....	47
Fitting the Coaxial Flue (Ø 60/100 Vertical).....	21	Electrical Unit.....	48
Fitting the Twin Pipe (Ø 80/80).....	22	Hydraulic Unit .....	50
Electrical Connections.....	25	Burner Unit.....	60
Peripheral Unit Connection .....	25	Annual Maintenance.....	64
Room Thermostat Connection.....	26	<b>Technical Information</b>	
Outdoor Sensor Connection .....	26	Technical Data E-COMBI ONE.....	66
Cylinder connection .....	26	Technical Data E-SYSTEM ONE .....	67
Electrical Diagram .....	27	ERP Data E-COMBI ONE .....	68
		Product fiche E-COMBI ONE .....	68
		ERP Data E-SYSTEM ONEE .....	69
		Product fiche E-SYSTEM ONE.....	69
		Package Label - Instuctions to filling.....	70
		Package fiche .....	72
		<b>Benchmark Commissioning &amp; Warranty Validation Service Record</b> .....	75

These instructions are suitable for E-COMBI ONE/E-SYSTEM ONE boilers :  
Do not forget to complete the Benchmark Commissioning Checklist!



#### The Benchmark Scheme

Benchmark places responsibilities on both manufacturers and installers. The purpose is to ensure that customers are provided with the correct equipment for their needs, that it is installed, commissioned and serviced in accordance with the manufacturer's instructions by competent persons and that it meets the requirements of the appropriate Building Regulations. The Benchmark Checklist can be used to demonstrate compliance with Building Regulations and should be provided to the customer for future reference.

Installers are required to carry out installation, commissioning and servicing work in accordance with the Benchmark Code of Practice which is available from the Heating and Hotwater Industry Council who manage and promote the Scheme. Visit [www.benchmark.org.uk](http://www.benchmark.org.uk) for more information.

#### To The Installer

As part of the commissioning of this appliance it is vital that the Benchmark Commissioning Checklist is completed and given to the Householder. Please ensure that your customer is aware of the importance of keeping the Benchmark Commissioning Checklist and Service Interval Record safe to document the product's history.

Please ensure that your customer is aware of the correct operation of the system, boiler and controls.

ARISTON recommend the use of protective clothing, when installing and working on the appliance i.e. gloves.

#### CUSTOMER CARE

ARISTON, as a leading manufacturer of domestic and commercial water heating appliances is committed to providing high quality products and a high quality after sales service.

Advice on installation or servicing can also be obtained by contacting the ARISTON Technical and Customer Service Departments at High Wycombe.

#### TECHNICAL DEPARTMENT

Tel: 0333 240 7777

Fax: 01494 459775

#### CUSTOMER SERVICE DEPARTMENT

Tel: 0333 240 8777

Fax: 01494 459775

#### CAUTION

In the United Kingdom, installation, start-up, adjustments and maintenance, must be performed by a competent person only, in accordance with the current Gas Safety (Installation & Use) Regulations and the instructions provided.

In the Republic of Ireland, the installation and initial start up of the appliance must be carried out by a Competent Person in accordance with the current edition of I.S.813 "Domestic Gas Installations", the current Building Regulations, reference should also be made to the current ETCl rules for electrical installation.

**All GAS SAFE registered installers carry a GAS SAFE ID card, and have a registration number. Both should be recorded in your boiler Benchmark Commissioning Checklist. You can check your installer is GAS SAFE registered by calling GAS SAFE directly on:- 0800 408 5500.**

Improper installation may cause damage or injury to individuals, animals and personal property for which the manufacturer will not be held liable. To ensure efficient and safe operation it is recommended that the boiler is serviced annually by a competent person.

If it is known that a fault exists on the appliance, it must not be used until the fault has been corrected by a competent person.

Please refer to the terms and conditions of warranty in the user manual which are also available on our website.

This instruction booklet is especially designed for appliances installed in the UK and the Republic of Ireland

**ATTENTION!!**



**THE INSTALLATION AND FIRST IGNITION OF THE BOILER MUST BE PERFORMED BY GAS SAFE REGISTERED ENGINEER IN COMPLIANCE WITH GAS SAFETY (INSTALLATION & USE) REGULATIONS AND ALL OTHER NATIONAL REGULATIONS REGARDING INSTALLATION, AND IN CONFORMITY WITH ANY REQUIREMENTS ESTABLISHED BY LOCAL AUTHORITIES AND PUBLIC HEALTH ORGANISATIONS.**

**AFTER THE BOILER HAS BEEN INSTALLED, THE INSTALLER MUST ENSURE THAT THE END USER RECEIVES THE DECLARATION OF CONFORMITY AND THE OPERATING MANUAL, AND SHOULD PROVIDE ALL NECESSARY INFORMATION AS TO HOW THE BOILER AND THE SAFETY DEVICES SHOULD BE HANDLED.**

**Advice for the installer**

This appliance is designed to produce hot water for domestic use.

It should be connected to a heating system and a distribution network for domestic hot water, both of which must be compatible with its performance and power levels.

The use of the appliance for purposes other than those specified is strictly forbidden. The manufacturer cannot be held responsible for any damage caused by improper, incorrect and unreasonable use of the appliance or by the failure to comply with the instructions given in this manual.

Installation, maintenance and all other interventions must be carried out in full conformity with the governing legal regulations and the instructions provided by the manufacturer. Incorrect installation can harm persons, animals and possessions; the manufacturing company shall not be held responsible for any damage caused as a result. The boiler is delivered in a carton. Once you have removed all the packaging, make sure the appliance is intact and that no parts are missing. If this is not the case, please contact your supplier.

Keep all packaging material (clips, plastic bags, polystyrene foam, etc.) out of reach of children as it may present a potential hazard.

In the event of a fault and/or malfunction, turn the appliance off, turn off the gas cock and do not attempt to repair it yourself. Contact a qualified professional instead.

Before any maintenance or repair work is performed on the boiler, make sure you have disconnected it from the electricity supply by switching the external bipolar switch to the "OFF" position and removing the fuse.

All repairs, which should only be performed using original spare parts, should be carried out by a qualified professional. Failure to comply with the above instructions could compromise the safety of the appliance and invalidate all liability on the part of the manufacturer.

In the event of any maintenance or other structural work in the immediate vicinity of the ducts or flue gas exhaust devices and their accessories, switch the appliance off by switching the external bipolar switch to the "OFF" position and shutting off the gas control valve. When the work has been completed, ask a

qualified technician to check the efficiency of the ducting and the devices.

Turn the boiler off and turn the external switch "OFF" to clean the exterior parts of the appliance.

Clean using a cloth dampened with soapy water. Do not use aggressive detergents, insecticides or toxic products. If the appliance is used in full compliance with current legislation, it will operate in a safe, environmentally-friendly and cost-efficient manner.

If using kits or optional extras, make sure they are authentic.

**Symbols used on the data plate**

1				2			
3			4		5		
6				7			
8		9		10		11	
12		13		14		15	
16		17		18		19	
20		21		22			

**Legend :**

- |   |   |
|---|---|
| 1. Brand                                | 14. Input rating nominal heating        |
| 2. Manufacturer                         | 15. Power output heating                |
| 3. Boiler model<br>Serial number        | 16. DHW specific flow rate              |
| 4. Commercial reference                 | 17. Boiler output efficiency            |
| 5. Certification number                 | 18. Input rating nominal DHW            |
| 6. Destination country<br>Gas category  | 19. Gases which may be used             |
| 7. Gas setting                          | 20. Minimum ambient temperature for use |
| 8. Installation type                    | 21. Max. central heating temperature    |
| 9. Electrical data                      | 22. Max. domestic hot water temperature |
| 10. Maximum domestic hot water pressure |   |
| 11. Maximum heating pressure            |   |
| 12. Boiler type                         |   |
| 13. NOx class / Efficiency              |   |

## SAFETY REGULATION

Key to symbols:



Failure to comply with this warning implies the risk of personal injury, in some circumstances even fatal



Failure to comply with this warning implies the risk of damage, in some circumstances even serious, to property, plants or animals.

**Install the appliance on a solid wall which is not subject to vibration.**

Noisy operation.



**When drilling holes in the wall for installation purposes, take care not to damage any electrical wiring or existing piping.**

Electrocution caused by contact with live wires. Explosions, fires or asphyxiation caused by gas leaking from damaged piping.



Damage to existing installations.



Flooding caused by water leaking from damaged piping.

**Perform all electrical connections using wires which have a suitable section.**

Fire caused by overheating due to electrical current passing through undersized cables.



**Protect all connection pipes and wires in order to prevent them from being damaged.**

Electrocution caused by contact with live wires. Explosions, fires or asphyxiation caused by gas leaking from damaged piping.



Flooding caused by water leaking from damaged piping.



**Make sure the installation site and any systems to which the appliance must be connected comply with the applicable norms in force.**

Electrocution caused by contact with live wires which have been installed incorrectly.



Damage to the appliance caused by improper operating conditions.



**Use suitable manual tools and equipment (make sure in particular that the tool is not worn out and that its handle is fixed properly); use them correctly and make sure they do not fall from a height. Replace them once you have finished using them.**

Personal injury from the falling splinters or fragments, inhalation of dust, shocks, cuts, pricks and abrasions.



Damage to the appliance or surrounding objects caused by falling splinters, knocks and



incisions.

**Use electrical equipment suitable for its intended use (in particular, make sure that the power supply cable and plug are intact and that the parts featuring rotary or reciprocating motions are fastened correctly); use this equipment correctly; do not obstruct passageways with the power supply cable, make sure no equipment could fall from a height. Disconnect it and replace it safely after use.**

Personal injury caused by falling splinters or fragments, inhalation of dust, knocks, cuts, puncture wounds, abrasions, noise and vibration.



Damage to the appliance or surrounding objects caused by falling splinters, knocks and incisions.



**Make sure any portable ladders are positioned securely, that they are suitably strong and that the steps are intact and not slippery and do not wobble when someone climbs them. Ensure someone provides supervision at all times.**

Personal injury caused by falling from a height or cuts (stepladders shutting accidentally).



**Make sure any rolling ladders are positioned securely, that they are suitably strong, that the steps are intact and not slippery and that the ladders are fitted with handrails on either side of the ladder and parapets on the landing.**

Personal injury caused by falling from a height.



**During all work carried out at a certain height (generally with a difference in height of more than two metres), make sure that parapets are used to surround the work area or that individual harnesses are used to prevent falls. The space where any accidental fall may occur should be free from dangerous obstacles, and any impact upon falling should be cushioned by semi-rigid or deformable surfaces.**

Personal injury caused by falling from a height.



**Make sure the workplace has suitable hygiene and sanitary conditions in terms of lighting, ventilation and solidity of the structures.**

Personal injury caused by knocks, stumbling etc.



**Protect the appliance and all areas in the vicinity of the work place using suitable material.**

Damage to the appliance or surrounding objects caused by falling splinters, knocks and incisions.



**Handle the appliance with suitable protection and with care.**

Damage to the appliance or surrounding objects from shocks, knocks, incisions and squashing. 

**During all work procedures, wear individual protective clothing and equipment.**

Personal injury caused by electrocution, falling splinters or fragments, inhalation of dust, shocks, cuts, puncture wounds, abrasions, noise and vibration. 

**Place all debris and equipment in such a way as to make movement easy and safe, avoiding the formation of any piles which could yield or collapse.**

Damage to the appliance or surrounding objects from shocks, knocks, incisions and squashing. 

**All operations inside the appliance must be performed with the necessary caution in order to avoid abrupt contact with sharp parts.**

Personal injury caused by cuts, puncture wounds and abrasions. 

**Reset all the safety and control functions affected by any work performed on the appliance and make sure they operate correctly before restarting the appliance.**

Explosions, fires or asphyxiation caused by gas leaks or an incorrect flue gas exhaust. 

Damage or shutdown of the appliance caused by out-of-control operation. 

**Before handling, empty all components that may contain hot water, carrying out any bleeding if necessary.**

Personal injury caused by burns. 

**Descale the components, in accordance with the instructions provided on the safety data sheet of the product used, airing the room, wearing protective clothing, avoid mixing different products, and protect the appliance and surrounding objects.**

Personal injury caused by acidic substances coming into contact with skin or eyes; inhaling or swallowing harmful chemical agents. 

Damage to the appliance or surrounding objects due to corrosion caused by acidic substances. 

**If you detect a smell of burning or smoke, keep clear of the appliance, disconnect it from the electricity supply, open all windows and contact the technician.**

Personal injury caused by burns, smoke inhalation, asphyxiation. 

This appliance can be used by children aged from 8 years and above and person with reduced physical, sensory or mental capabilities or lack of experience and knowledge if they have been given supervision or instruction concerning use of the appliance in a safe way and understand the hazards involved. Children shall not play with the appliance. Cleaning and user maintenance shall not be made by children without supervision. 

### UKCA labelling

**The UKCA mark guarantee that the appliance conform to the following UK regulations:**

- Gas Appliances Regulation (Regulation (EU) 2016/426 as brought into GB law and amended) and the Gas Appliances (Enforcement) and Miscellaneous Amendment Regulations 2018 (S.I. 2018 No. 389, as amended)
- The Ecodesign for Energy-Related Products and Energy Information (Amendment) (EU Exit) Regulations 2019 (S.I. 2019 No. 539, as amended)
- BED (Boiler Efficiency Directive) - only art.7 ( 2), art.8 and annex III, IV, V
- Electrical Equipment (Safety) Regulations 2016 (S.I. 2016 No 1101, as amended)
- Electromagnetic Compatibility Regulations 2016 (S.I. 2016 No. 1091, as amended)
- The Restriction of the Use of Certain Hazardous Substances in Electrical and Electronic Equipment Regulations 2012 (S.I. 2012 No. 3031, as amended).

### CE labelling

**The CE mark guarantees that the appliance conforms to the following directives:**

- 2016/426/EU relating to gas appliances
- 2014/30/EU relating to electromagnetic compatibility
- 92/42/CEE relating to energy efficiency
- 2014/35/EU relating to electrical safety
- 2009/125/CE Energy related Products
- 813/2013 Commission regulation (EU)

CONTROL PANEL

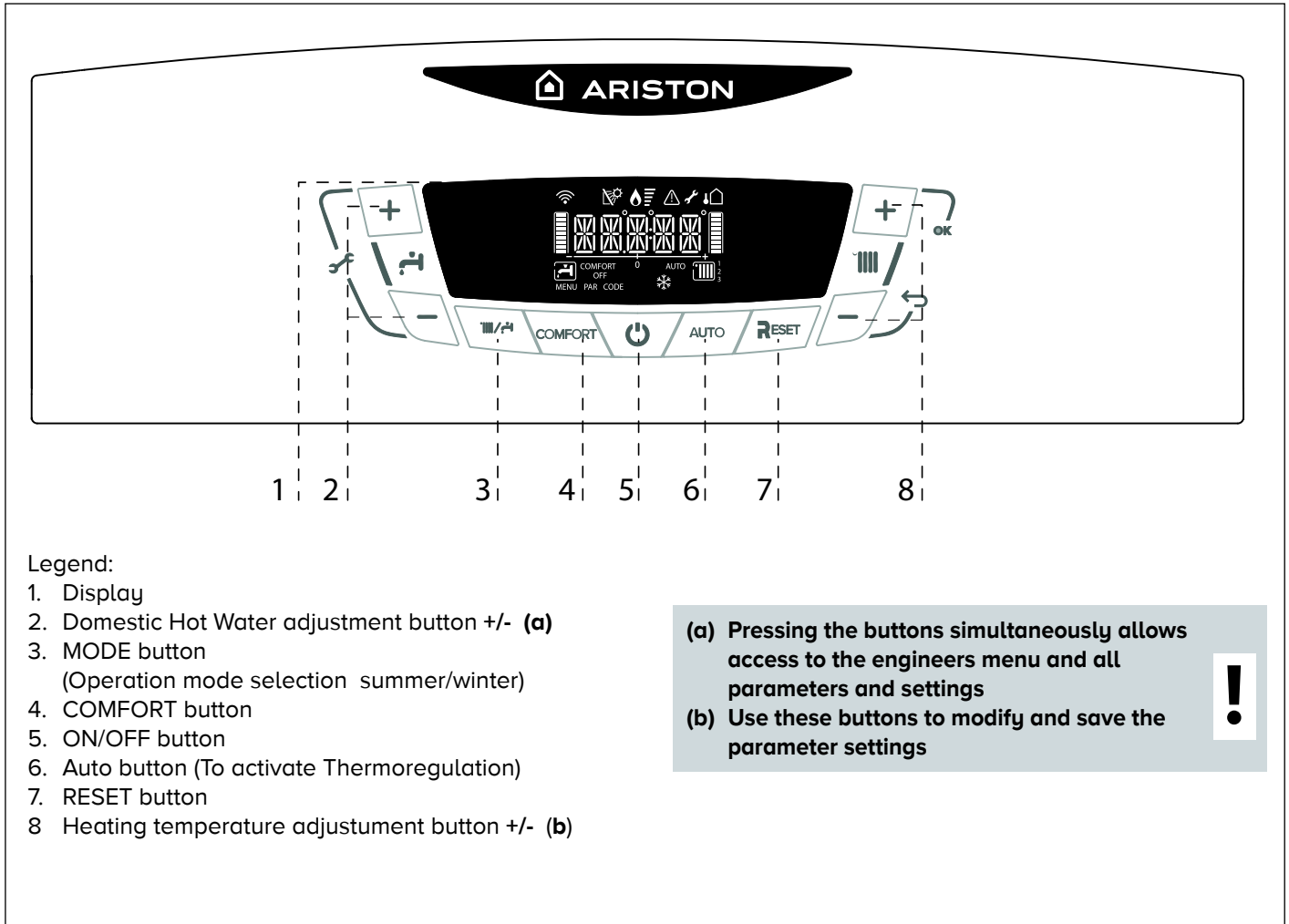

DISPLAY

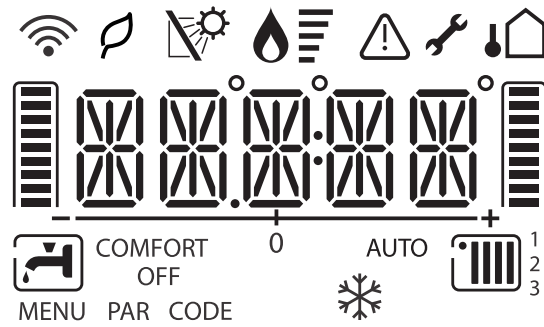

Legend:

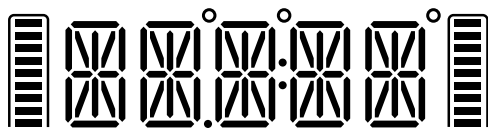

- Digits indicating:
- boiler status
  - temperature indication with bar level
  - error code signals (ERROR)
  - Request press **RESET** button (boiler block)
  - menu settings



Technical assistance request



Flame detected with indication of power used



Heating operation set



Heating operation active



Hot water operation set



Hot water operation active

COMFORT

Hot Water Comfort activated

OFF

Boiler off with antifreeze function active



Anti-frost Function Active

AUTO

AUTO function activated



High efficiency operation (low C.H. flow temperature)



Solar temperature probe connected - option



Error signals  
The display shows the code



External temperature displayed  
(with external sensor optional)



Wi-Fi active (Kit Optional)

Overall view

1. Flue connector
2. Air relief valve
3. C.H. Flow temperature probe
4. Main heat exchanger
5. Detection Electrode
6. Air/Gas Mixer
7. Secondary heat exchanger
8. Condensate trap
9. C.H. pressure relief valve
10. Gas valve
12. C.H. circuit filter
13. Modulating circulation Pump with air release valve
14. D.H.W. Flow switch
15. Diverter valve
16. Switch On-Off
17. C.H. Return temperature probe
18. Modulating Fan
19. Silencer
20. Combustion Analysis Test Point

E-COMBI ONE

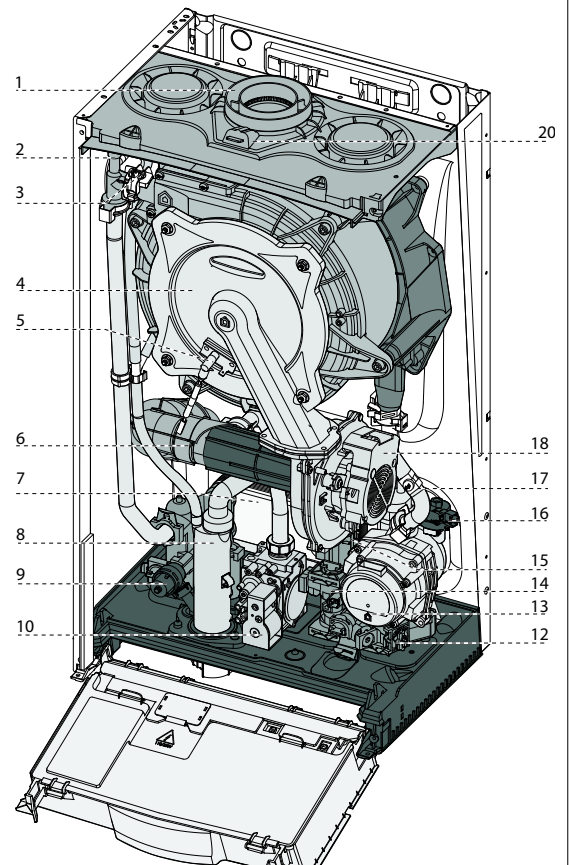

E-SYSTEM ONE

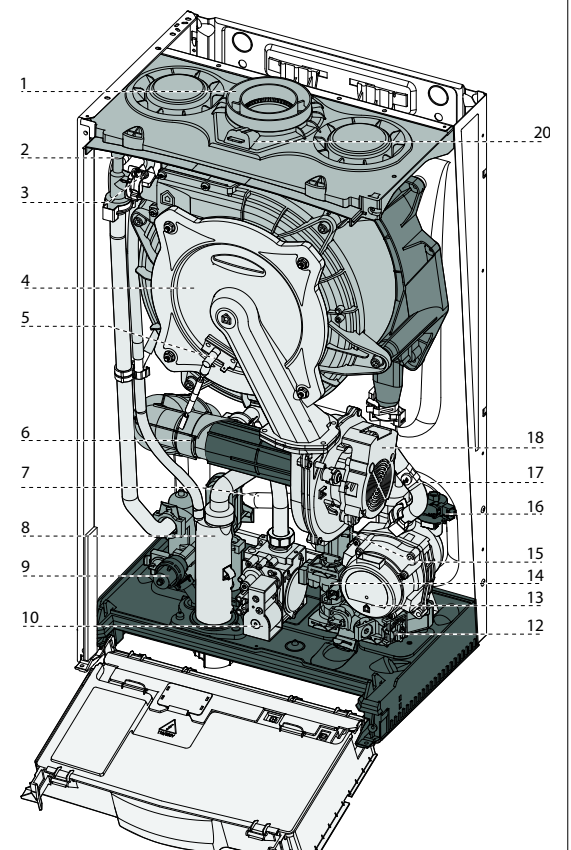

# PRODUCT DESCRIPTION

## Overall Dimensions

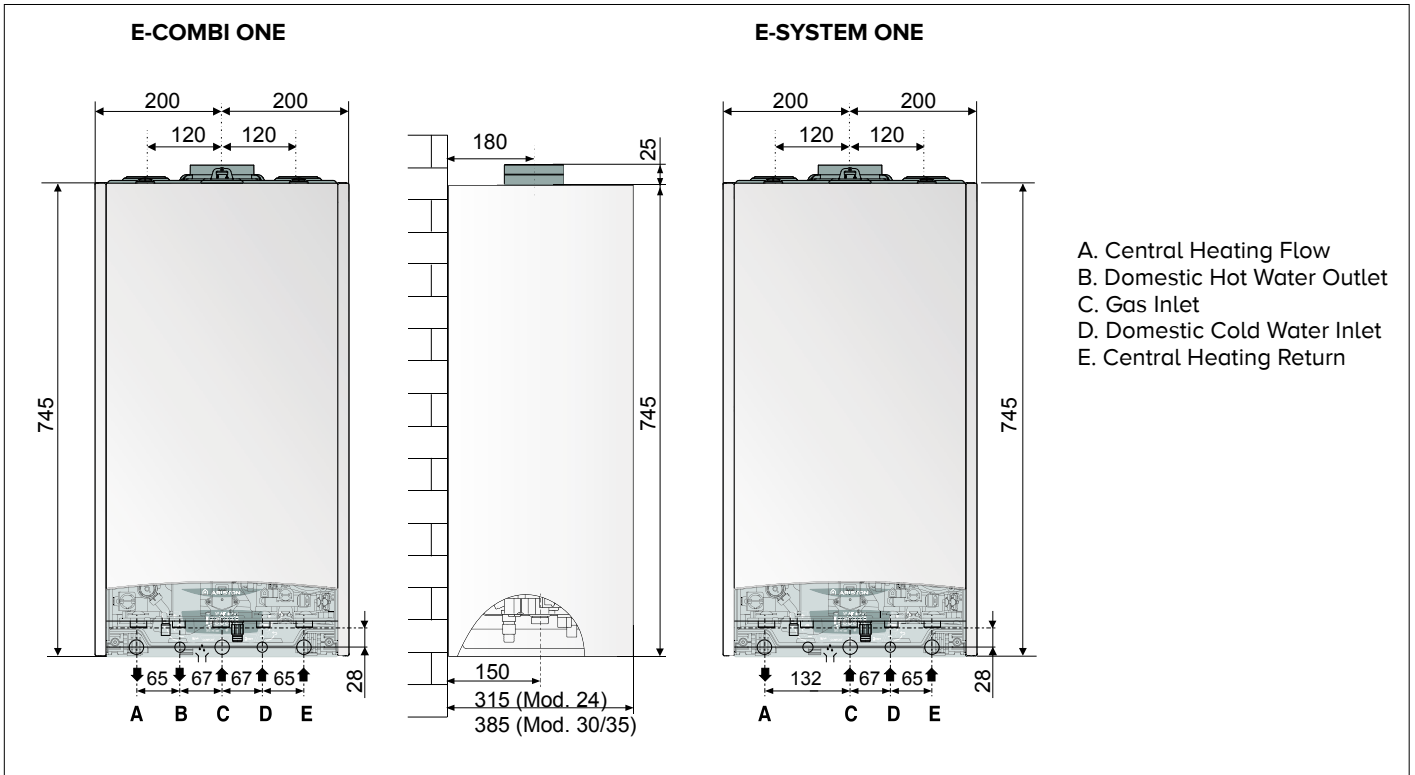

## Minimum clearances

In order to allow easy access to the boiler for maintenance operations, The boiler must be installed in accordance with the clearances stated below.

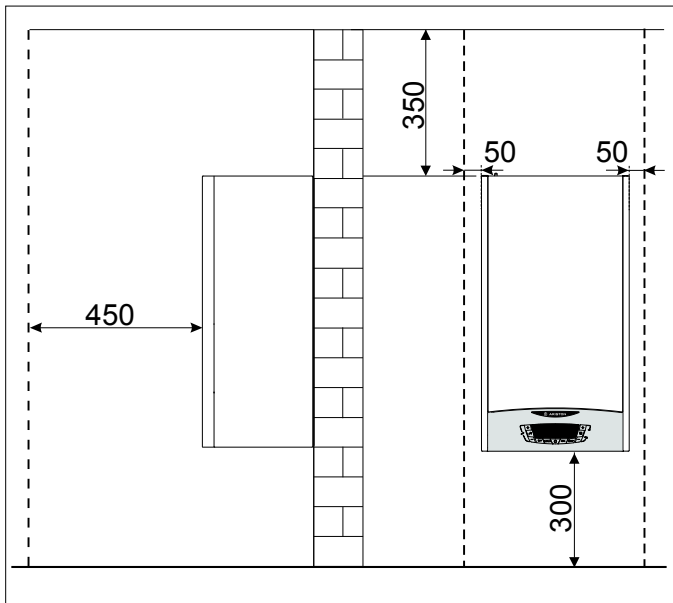

## Reference Standards

In the United Kingdom, the installation and initial start-up of the boiler must be by a Gas Safe registered installer in accordance with the installation standards currently in effect, as well as with any and all local health and safety standards i.e. Gas Safe.

In the Republic of Ireland the installation and initial start-up of the appliance must be carried out by a Competent Person in accordance with the current edition of I.S.813 "Domestic Gas Installations" and the current Building Regulations, reference should also be made to the current ETCl rules for electrical installation.

The installation of this appliance must be in accordance with the relevant requirements of the Local Building Regulations, the current I.E.E. Wiring Regulations, the by-laws of the local authority, in Scotland, in accordance with the Building Standards (Scotland) Regulation and Health and Safety document No. 635, "Electricity at Work Regulations 1989" and in the Republic of Ireland with the current edition of I.S. 813 and the Local Building Regulations (IE).

## C.O.S.H.H.

Materials used in the manufacture of this appliance are non-hazardous and no special precautions are required when servicing.

## Codes of Practice

Installation should also comply with the following British Standards Code of Practice (refer to the most recent version):

**BS 7593: Treatment of water in domestic hot water central heating systems**

**BS 5546: Installation of hot water supplies for domestic purposes**

**BS 5440-1: Flues**

**BS 5440-2: Air supply**

**BS EN 12831 - BS EN 14336:**

**Forced circulation hot water systems**

**BS 6798: Installation of gas fired hot water boilers of rated input not exceeding 70kW**

**BS 6891: Installation of low pressure gas pipes up to 28mm**

**BS 7671: IEE Wiring Regulations**

**BS 4814: Specification for expansion vessels**

**BS 5482: Installation of L.P.G.**

**Technical Bulletin TB143 Flue Gas Analysis**

and in the Republic of Ireland in accordance with the following codes of practice:

## I.S. 813 Domestic Gas Installations

Avoid installing the boiler where the air inlet can be polluted by chemical products such as chlorine (swimming pool area), or ammonia (hair dresser), or alkaline products (launderette).

## Flue

Detailed information on flue assembly can be found in the "Connecting the Flue" section.

The boiler must be installed so that the flue terminal is exposed to the free passage of external air at all times and must not be installed in a place likely to cause nuisance. It must not be allowed to discharge into another room or space such as an outhouse or closed lean-to.

Condensing boilers have a tendency to form a plume of water vapour from the flue terminal due to the low temperature of the flue gasses. The terminal should therefore be located with due regard for the damage or discolouration that may occur to building within the vicinity and consideration must also be given to adjacent boundaries, openable windows should also be taken into consideration when siting the flue.

The minimum acceptable clearances are shown below:

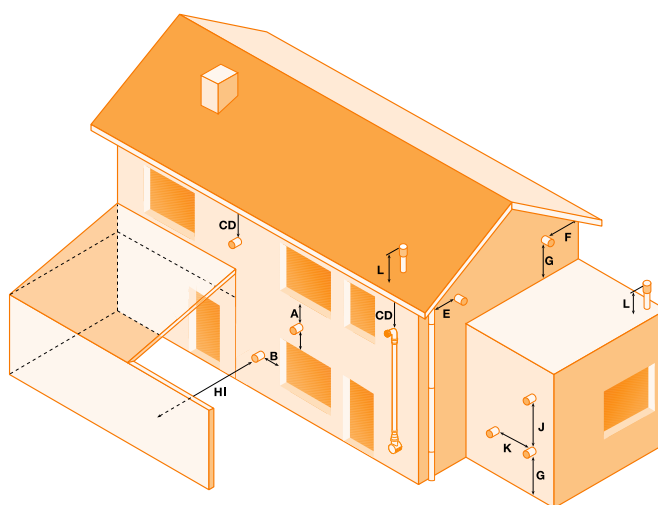

- A Directly below an opening, window, etc 300 mm
- B Horizontally to an opening, window, etc 300 mm
- C Below gutters, soils pipes or drain pipes 75 mm
- D Below eaves 200 mm
- E From vertical drain pipe or soil pipe 75 mm
- F From internal or external corner 300 mm
- G Above ground, roof or balcony level 300 mm
- H From a surface facing the terminal 600 mm
- I From a terminal facing a terminal 1200 mm
- J Vertically from a terminal on the same wall 1500 mm
- K Horizontally from an terminal on the same wall 300 mm
- L Fixed by vertical flue terminal

**NOTE: THE FLUE MUST NOT BE INSTALLED IN A PLACE LIKELY TO CAUSE A NUISANCE AND POSITIONED TO ENSURE THAT PRODUCTS OF COMBUSTION DO NOT DISCHARGE ACROSS A BOUNDARY**

It may be necessary to protect the terminal with a guard, if this is the case it will be necessary to purchase a stainless steel terminal guard. Reference should be made to the Building Regulations for guidance.

## Ventilation

The room in which the boiler is installed does not require specific ventilation. If the boiler is installed in a cupboard or compartment ventilation is not required for cooling purposes.

## INSTALLATION

### Gas Supply

The gas installation and tightness testing must be in accordance with the requirements of BS6891. Ensure that the pipe size is adequate for demand including other gas appliances on the same supply.

### Electrical Supply

The appliance requires an earthed 230V - 50 Hz supply and must be in accordance with current I.E.E. regulations. It must also be possible to be able to completely isolate the appliance electrically. Connection should be via a 3 amp double pole fused isolating switch with contact separation of at least 3mm on both poles. Alternatively, a fused 3 amp, 3 pin plug and unswitched socket may be used, provided it is not used in a room containing a bath or shower. It should only supply the appliance.

### Water Supply

The boiler is suitable for sealed systems only. The maximum working pressure for the appliance is 6 bar. All fittings and pipework for the appliance should be of the same standard. If there is a possibility of the incoming mains pressure exceeding 6 bar, particularly at night, then a suitable pressure limiting valve must be fitted.

The boiler is designed to provide hot water on demand to multiple outlets within the property. If there is a requirement for greater demands, for example if the boiler has several bathrooms and cloakrooms, a vented or unvented hot water storage system may be used.

### Showers

Any shower valves used with the appliance should be of a thermostatic or pressure balanced type. Refer to the shower manufacturer for performance guidance and suitability.

### Flushing and Water Treatment

The boiler is equipped with a stainless steel heat exchanger.

The detailed recommendations for water treatment are given in BS 7593 (Treatment of water in domestic hot water central heating systems); the following notes are given for general guidance.

If the boiler is installed on an existing system, any unsuitable additives must be removed.

Under no circumstances should the boiler be fired before the system has been thoroughly flushed; the flushing procedure must be in line with BS 7593.

We highly recommend the use of a flushing detergent appropriate for the metals used in the circuit.

In hard water areas or where large quantities of water are in the system the treatment of water to prevent premature scaling of the main exchanger is necessary.

The formation of scale heat compromises the efficiency of the thermic exchanger because small areas of scale cause a high increase of the temperature of the metallic walls and therefore add to the thermal stress of the heat exchanger.

Demineralised water is more aggressive so in this situation it is necessary to treat the water with an appropriate corrosion inhibitor.

Any treatment of water by additives in the system for frost protection or for corrosion inhibition has to be absolutely suitable for all metals used in the circuit.

The use of a corrosion inhibitor in the system is recommended to prevent corrosion (sludge) damaging the boiler and system;

If anti-freeze substances are to be used in the system, check carefully that they are compatible with the metals used in the circuit.

ARISTON suggests the use of suitable anti-freeze products, which will prevent rust and incrustation taking place.

Periodically check the pH balance of the water/anti-freeze mixture of the boiler circuit and replace it when the amount measured is out of the range stipulated by the manufacturer (7 < pH < 8).

**DO NOT MIX DIFFERENT TYPES OF ANTI-FREEZE**

In under-floor systems, the use of plastic pipes without protection against penetration of oxygen through the walls can cause corrosion of the systems metal parts (metal piping, boiler etc), through the formation of oxides and bacterial agents.

To prevent this problem it is necessary to use pipes with an "oxygen proof barrier", in accordance with standards DIN 4726/4729. **If pipes of this kind are not used, keep the system separate by installing heat exchangers of those with a specific system water treatment.**

Ariston suggests the installation of a magnetic filter on every installation.

### IMPORTANT

**Failure to carry out the water treatment procedure will invalidate the appliance guarantee.**

### System Controls

The boiler is electrically controlled and is suitable for most modern electronic time and temperature controls. The addition of such external controls can be beneficial to the efficient operation of the system. The boiler connections for external controls are 12V DC and so only controls of 12V DC that have voltage free contacts should be used. (page 26).

ARISTON supply a range of wired and wireless system controls. Contact your supplier for more details.

### Location

The boiler can be installed on any suitable internal wall (suitable sound proofing may be required when installing onto a stud partition wall). Provision must be made to allow for the correct routing of the flue and siting of the terminal to allow the safe and efficient removal of the flue products. A compartment or cupboard may be used provided that it has been built or modified for this purpose. It is not necessary to provide permanent ventilation for cooling purposes. Detailed recommendations are given in BS 5440 Part 2. If it is proposed that it is to be installed in a timber framed building then reference should be made to IGEM Document, IGE/UP/7 or advice sought from Gas Safe.

**Where a room sealed appliance is installed in a room containing a bath or shower, the appliance and any electrical switch or appliance control, utilising mains electricity should be situated specifically in accordance with current IEE Wiring Regulations.**

For unusual locations, special procedures may be necessary. **BS 6798** gives detailed guidance on this aspect.

**Codensate Discharge**

The condensate discharge hose from the boiler must have a continuous fall of 2.5° and must be inserted by at least 50mm into a suitable acid resistant pipe - e.g. plastic waste or overflow pipe. The condensate discharge pipe must have a minimum diameter of 22mm, must have a continuous fall and preferably be installed and terminated to prevent freezing. The discharge pipe must be terminated in a suitable position:

- i) Connecting into an internal soil stack (at least 450mm above the invert of the stack). A trap giving a water seal of at least 75mm must be incorporated into the pipe run, there also must be an air beak upstream of the trap.
- ii) Connecting into the waste system of the building such as a washing machine or sink trap. The connection must be upstream of the washing machine/sink. If the connection is downstream of the waste trap then an additional trap giving a minimum water seal of 75mm and an air break must be incorporated in the pipe run, as above.
- iii) Terminating into a gully, below the grid level but above the water level
- iv) Into a soakaway

Note: If any condensate pipework is to be installed externally then it should be kept to a minimum and be insulated with a waterproof insulation and have a continuous fall. The total length of external pipe used should not exceed 3 metres.

Some examples of the type of condensate terminations can be found below.

**1. Internal termination of condensate drainage pipe to internal stack.**

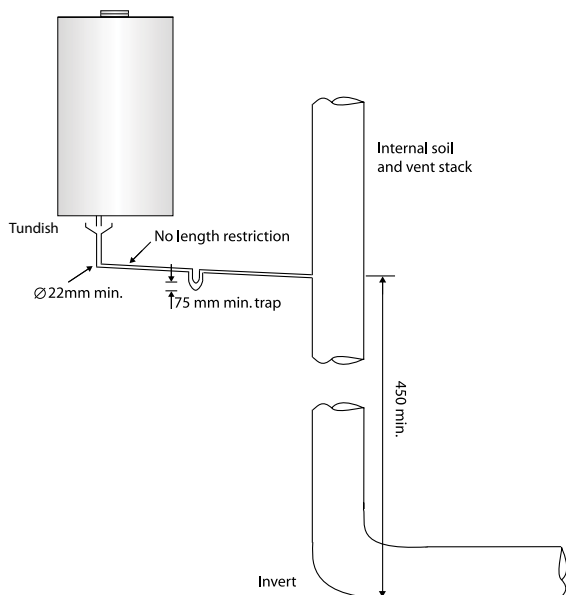

**Condensate Discharge**

Push fit the flexible condensate pipe into the outlet spigot on the appliance. Cut to length and locate outlet into a tundish

**2. External termination of condensate drainage pipe via internal discharge branch (e.g. sink waste) and condensate siphon.**

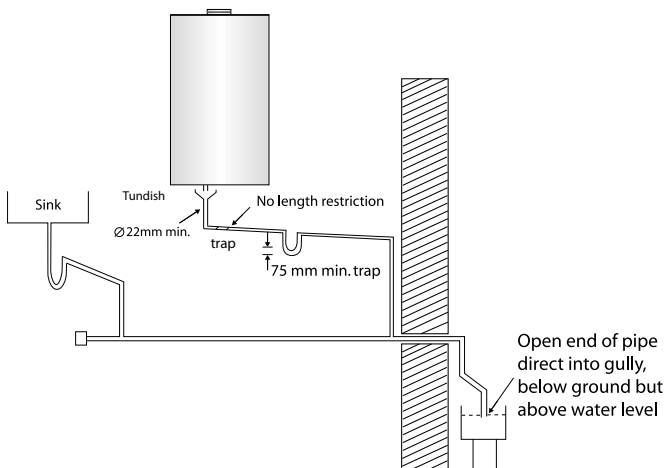

**3. External termination of condensate drainage pipe via internal discharge branch (e.g. sink waste - proprietary fitting).**

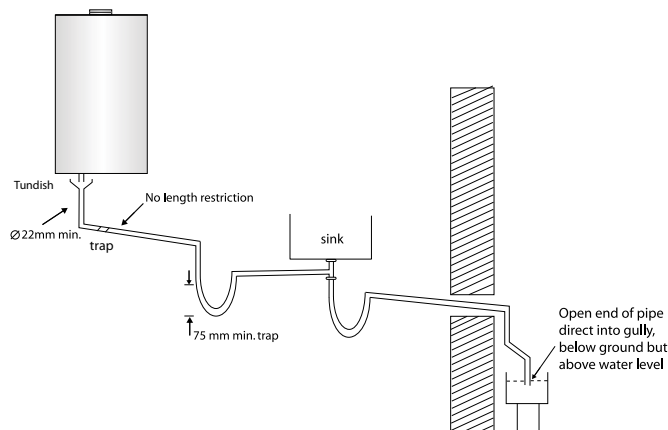

**4. External termination of condensate drainage pipe via condensate siphon**

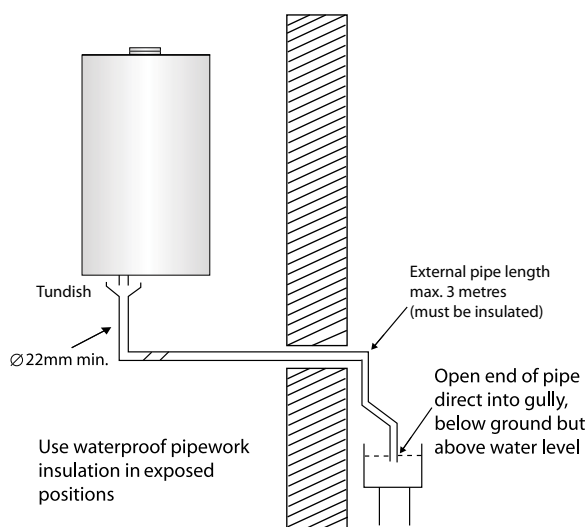

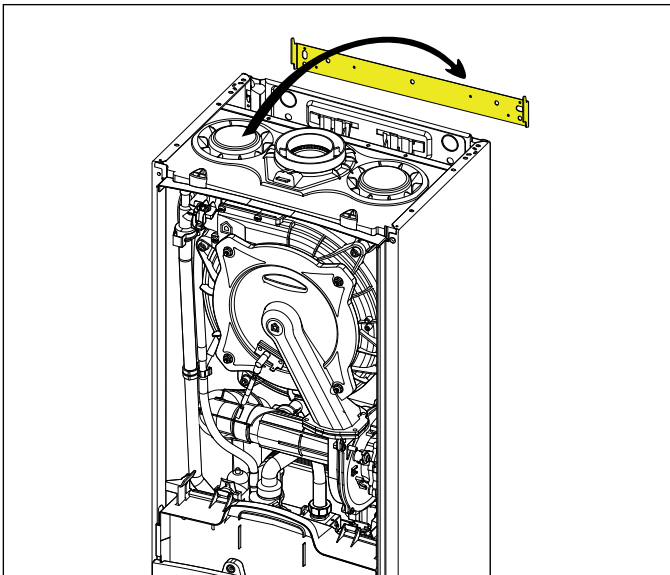

## Installing the Boiler

Please check that you are familiar with the installation requirement before commencing work (pages 11 - 15).

The installation accessories described in the following list are included in the boiler packaging:

- Hanging bracket
- A paper template (showing the dimensions of the boiler with 5 mm side clearances)
- Connection valves (compression)
- Screws and washers
- Filling loop
- Installation, Servicing and User manual

## Method of positioning the boiler on the wall

The paper template can be used to ensure the correct positioning of kitchen cabinets etc.

The paper template has to be fixed to the wall and used to locate the position of the hanging bracket and the centre for the flue hole.

Drill and plug the wall and secure the hanging bracket using the screws provided ensure the hanging bracket is level. Remove the boiler from its packaging and remove the front casing panel. Place the boiler on the hanging bracket.

**NOTE: THE APPLIANCE MUST NOT BE FITTED ON A COMBUSTIBLE WALL SURFACE.**

## Connecting the boiler to the system

- Remove the boiler casing as described on page 14
- Remove the caps and connect the valves to the boiler using the washers provided
- 5 x fibre washers for the CH flow and return, cold water inlet, gas and hot water outlet connections

## Safety Valve Discharge

The pressure relief valve pipe is made of copper. It should terminate below the boiler safely outside the premises. Care should be taken that it does not terminate over an entrance or window or where a discharge of heated water could endanger occupants or passers by.

## WARNING!

**DO NOT APPLY HEAT TO THE COPPER SAFETY VALVE OUTLET PIPE WHILST IT IS CONNECTED TO THE 3 BAR SAFETY RELIEF VALVE.**



Fill the central heating and DHW system and bleed air from the system as described in the Commissioning instructions (page 32).

The system should be carefully checked for leaks, as frequent refilling could cause premature system corrosion or unnecessary scaling of the heat exchanger. The pipe from the trap should be connected to a drain as described in the relevant regulations.

Pay special attention not to bend the condensate silicone drain pipe in such a way as to interrupt the flow. Please only use drain pipe material compatible with condensate products (refer to BS 6798:2009).

The condensate flow can reach **2 litres/hour** because of the acidity of the condensate products (Ph close to 2), take care before operation.

See page 15 for condensate discharge options.

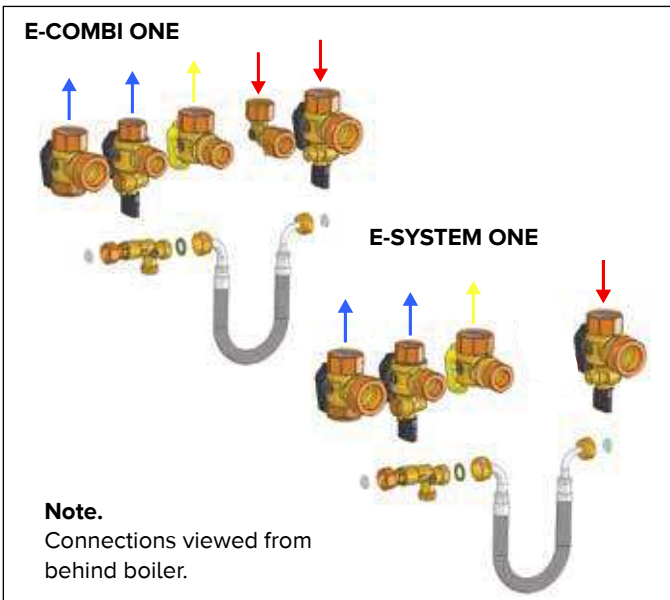

**Gas connection**

Make sure, using the labels on the packaging and the data plate on the appliance itself, that the boiler is in the correct country and that the gas category for which the boiler was designed corresponds to one of the categories available in the country where it will be used.

The gas supply piping must be created and measured out in compliance with specific legal requirements and in accordance with the maximum power of the boiler.

Check that the supplied gas corresponds to the type of gas for which the boiler was designed (see the data plate located on the appliance itself).

It is also important to check that the pressure of the gas (methane or LPG) you will be using to feed the boiler is suitable, because if it is insufficient the power may be reduced, causing inconvenience for the user.

**Water connection**

The illustration below shows the connections for the water and gas attachments of the boiler. See valves configuration on page 14.

Check that the maximum water mains pressure does not exceed 6 bar; if it does, a pressure reducing valve must be installed.

For the measuring of the pipes and of the heating bodies in the heating system, the residual head value should be calculated as a function of the requested flow rate, in accordance with the values shown in the circulation pump graph.

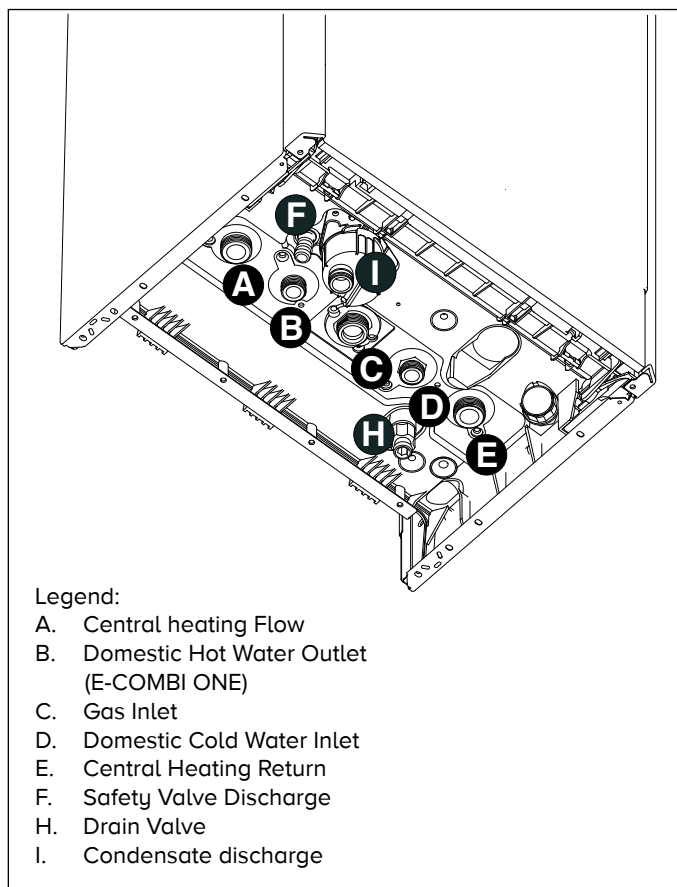

**Instructions for removing the housing and inspecting the appliance.**

Before carrying out any work on the boiler, switch off the power supply using the external bipolar switch and close the gas tap.

To access the inside of the boiler:

- unscrew the two screws from the front panel (a), pull the panel forwards and uncouple it from the upper pins (b),
- pivot the electronic unit by pulling it forwards (c).

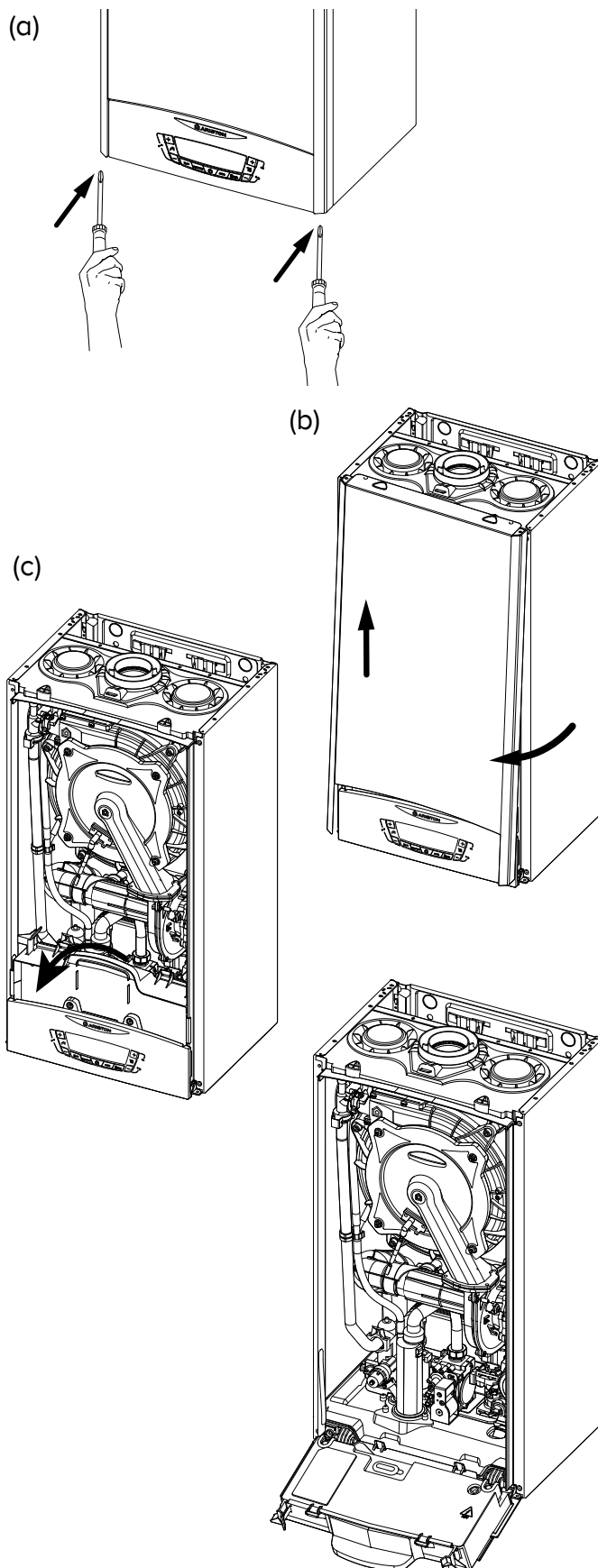

## INSTALLATION

To calculate the size of the heating installation, refer to the "Available pressure" graph below.

**Graph representing the available circulation pump pressure  $\Delta T 20^{\circ}\text{C}$**

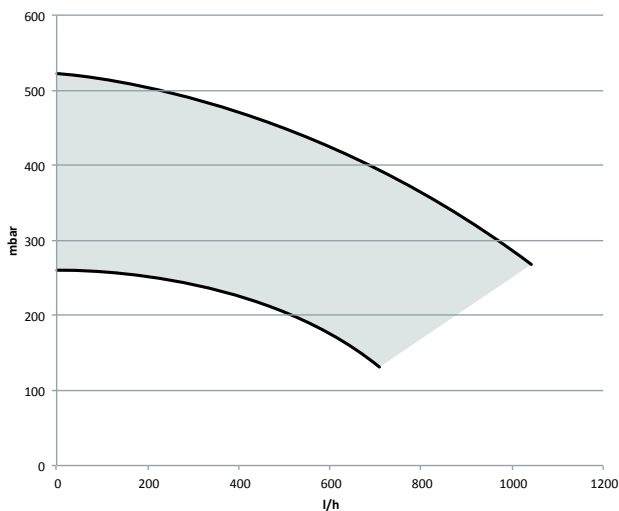

**BEFORE THE DEVICE IS USED, FOR THE FIRST TIME THE TRAP MUST BE FILLED WITH WATER. ⚠**

The siphon is filled with water during deaeration procedure of the boiler (or heating system) - see p. 32

Ensure that the siphon contains water; if not, it must be refilled. Open the manual air vent (2) on the main exchanger until complete filling. Check again the system pressure ⚠ on the pressure gauge.

**WARNING!**  
**INSUFFICIENT WATER IN THE TRAP CAN TEMPORARILY CAUSE THE FLUE GAS TO BE EXPELLED INTO THE SURROUNDING AMBIENT AIR**

### Underfloor heating

For appliances with underfloor heating, it is possible but not necessary to fit a safety thermostat onto the underfloor heating outlet. For the electrical connection of the thermostat see the section on "Electrical connections - pages 28-29".

If the outlet temperature is too high, the boiler will stop both domestic hot water and the heating production and the error code 1 16 "floor thermostat contact open" will appear on the display. The boiler will restart when the thermostat is closed during automatic resetting.

If the thermostat cannot be installed, the underfloor heating equipment must be protected by a thermostatic valve, or by a bypass to prevent the floor from reaching too high a temperature.



Water circuit diagram

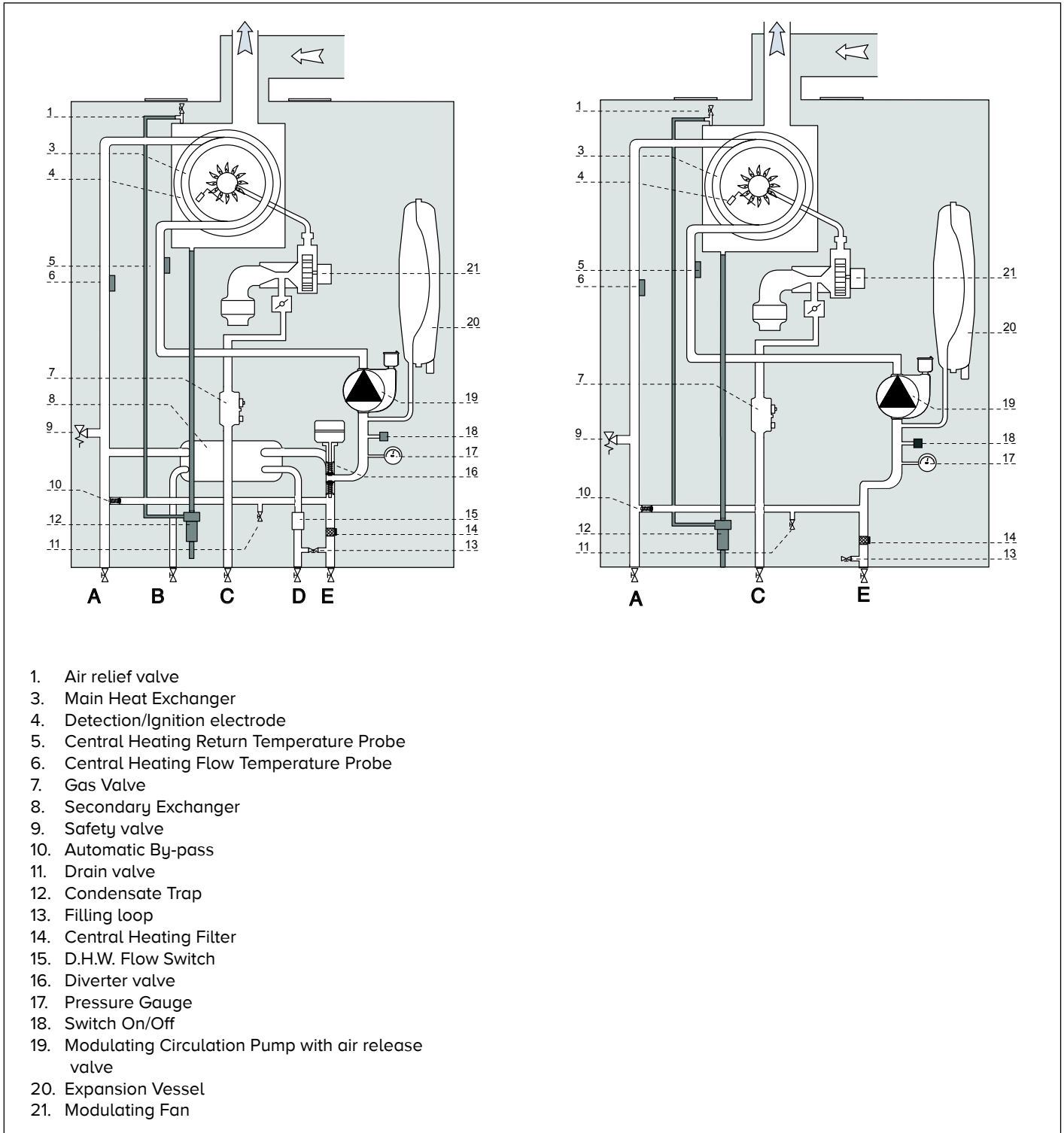

## INSTALLATION

### Connecting the Flue

#### Flue System

The provision for satisfactory flue termination must be made as described in BS 5440-1.

The appliance must be installed so that the flue terminal is exposed to outdoor air.

The terminal must not discharge into another room or space such as an outhouse or lean-to.

It is important that the position of the terminal allows a free passage of air across it at all times.

The terminal should be located with due regard for the damage or discolouration that might occur on buildings in the vicinity, it must also be located in a place not likely to cause nuisance.

In cold or humid weather water vapour may condense on leaving the flue terminal.

The effect of such "steaming" must be considered.

If the terminal is less than 2 metres above a balcony, above ground or above a flat roof to which people have access, then a suitable stainless steel terminal guard must be fitted.

The minimum acceptable spacing from the terminal to obstructions and ventilation openings are specified in Fig. 1.

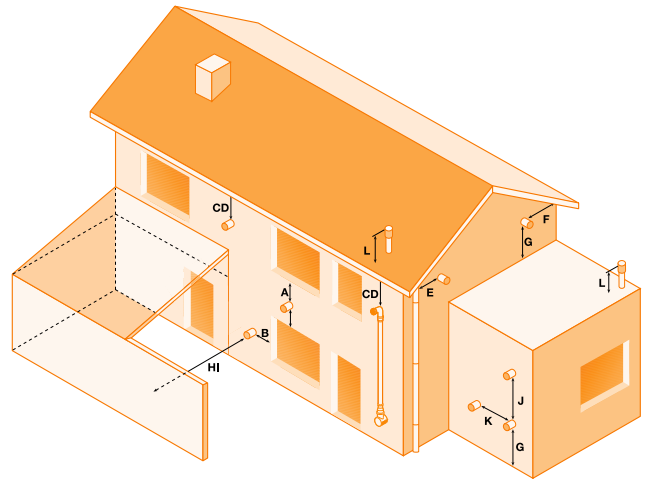

Fig. 1

- |   |         |
|---|---------|
| - A Directly below an opening, window, etc        | 300 mm  |
| - B Horizontally to an opening, window, etc       | 300 mm  |
| - C Below gutters, soils pipes or drain pipes     | 75 mm   |
| - D Below eaves                                   | 200 mm  |
| - E From vertical drain pipe or soil pipe         | 75 mm   |
| - F From internal or external corner              | 300 mm  |
| - G Above ground, roof or balcony level           | 300 mm  |
| - H From a surface facing the terminal            | 600 mm  |
| - I From a terminal facing a terminal             | 1200 mm |
| - J Vertically from a terminal on the same wall   | 1500 mm |
| - K Horizontally from a terminal on the same wall | 300 mm  |
| - L Fixed by vertical flue terminal               |         |

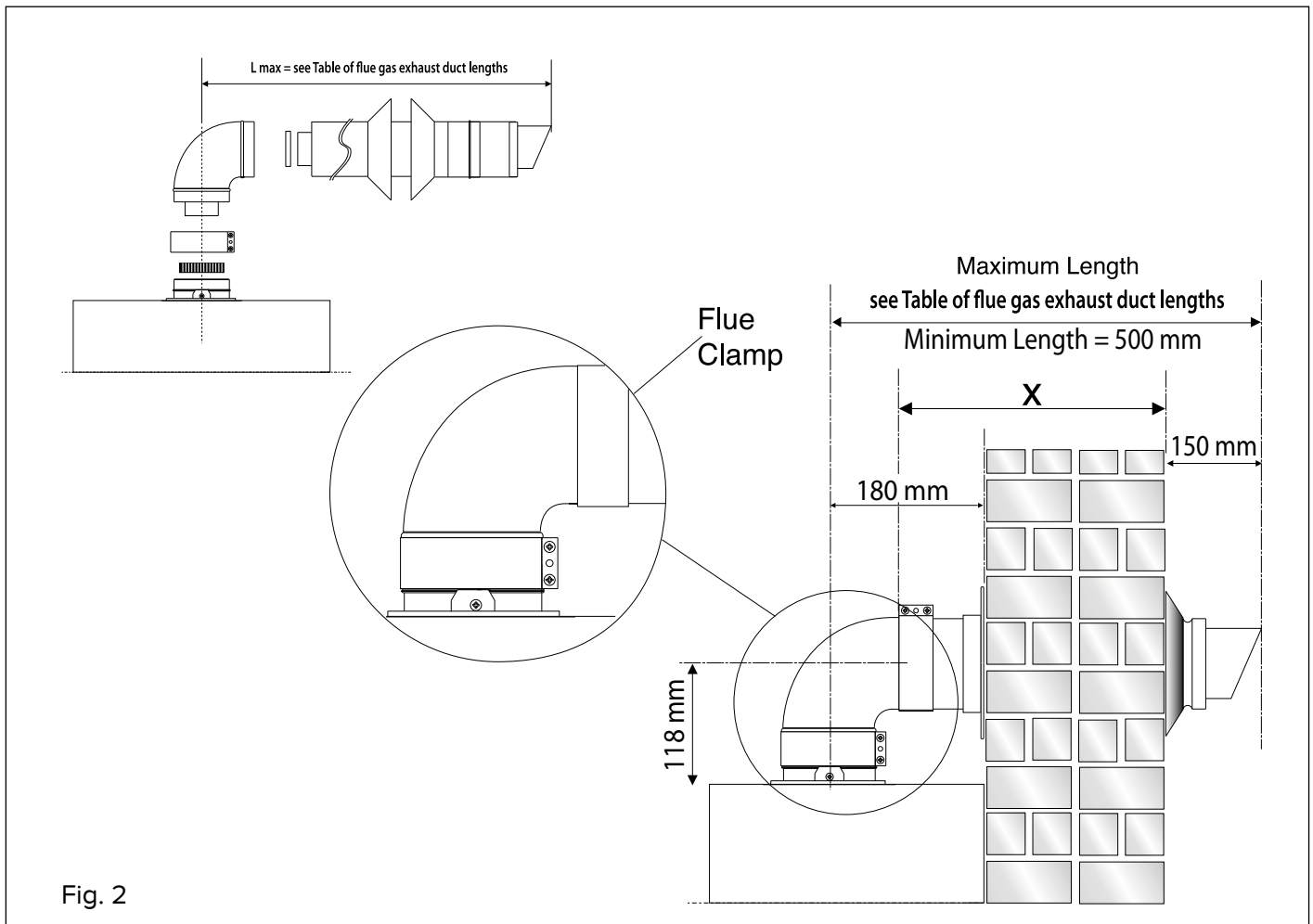

Fig. 2

## Warning

The exhaust gas ducts must not be in contact with or close to inflammable material and must not pass through building structures or walls made of inflammable material. When replacing an old appliance, the flue system must be changed.

## Important

Ensure that the flue is not blocked. Ensure that the flue is supported and assembled in accordance with these instructions.

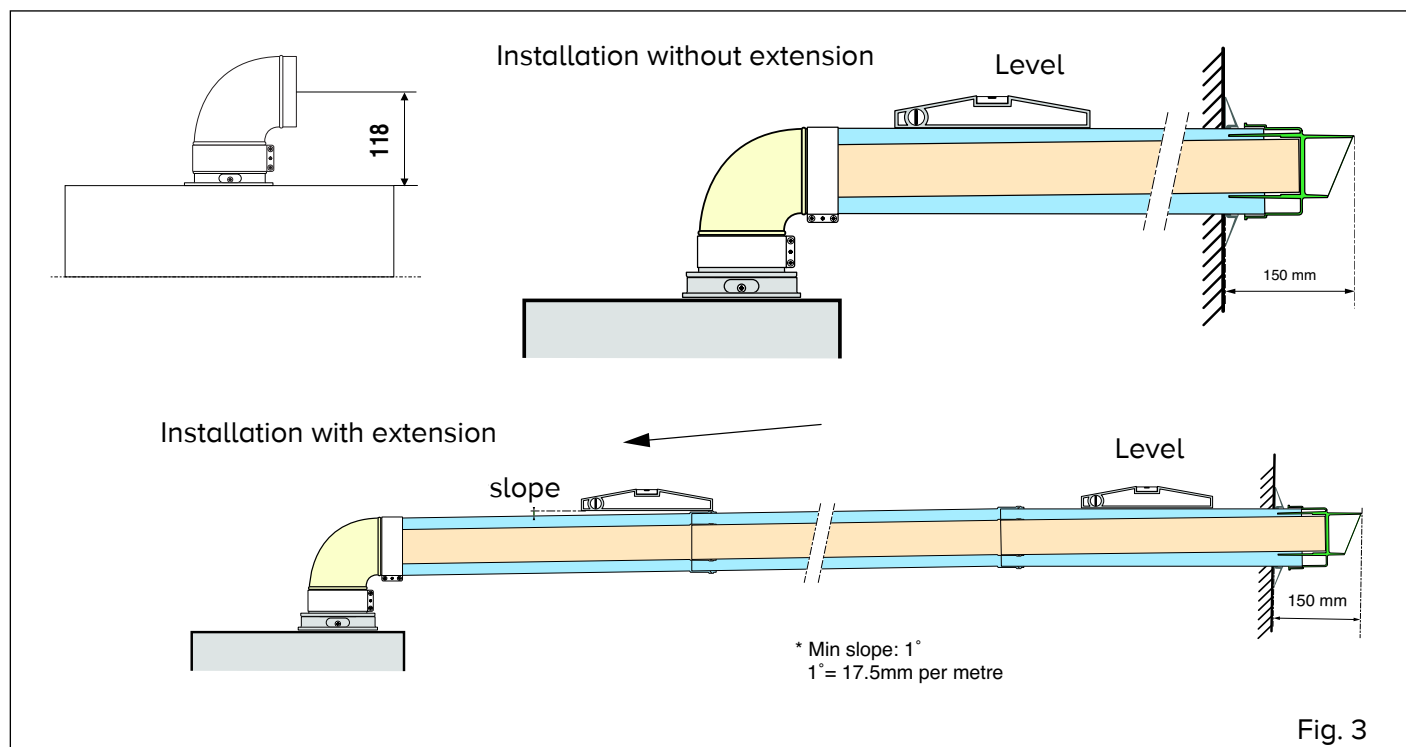

## Fitting the Coaxial Flue (Ø 60 / 100 Horizontal)

Contents:

- 1x Silicone O-Ring (60mm)
- 1x Elbow (90°)
- 2x Wall Seals (Internal & External)
- 1x Flue Pipe including Terminal (1 metre - 60/100)
- 2x Flue Clamps
- 4x Screws
- 2x Seals

Once the boiler has been positioned on the wall, fit the rubber flue seal into the internal flue turret (see diagram opposite),

Insert the elbow into the socket and rotate to the required position. note: It is possible to rotate the elbow 360° on its vertical axis.

Using the flue clamp, seals and screws supplied (Fig 4) secure the elbow to the boiler.

The 1 metre horizontal flue kit (3318073) supplied is suitable for an exact X dimension of 753mm.

Measure the distance from the face of the external wall to the face of the flue elbow (X - Fig 2), this figure must now be subtracted from 753mm, you now have the total amount to be cut from the plain end of the flue.

**Note:** A Plume management kit is available for 60/100 horizontal termination. Instructions for installation are supplied with the Plume management kit.

Draw a circle around the outer flue and cut the flue to the required length taking care not to cut the inner flue, next cut the inner flue ensuring that the length between the inner and outer flue is maintained. (Fig 4).

e.g.

$$X = 555\text{mm}$$

$753 - 555 = 198\text{mm}$  (Length to be cut from the plain end of the flue).

Once cut to the required length, ensure that the flue is free from burrs and reassemble the flue. If fitting the flue from inside of the building attach the outer wall seal to the flue terminal and push the flue through the hole, once the wall seal has passed through the hole, pull the flue back until the seal is flush with the wall. Alternatively, the flue can be installed from outside of the building, the outer seal being fitted last.

Should the flue require extending, the flue connections are push fit, however, one flue bracket should be used to secure each metre of flue.

Note: See table for maximum and minimum flue runs.

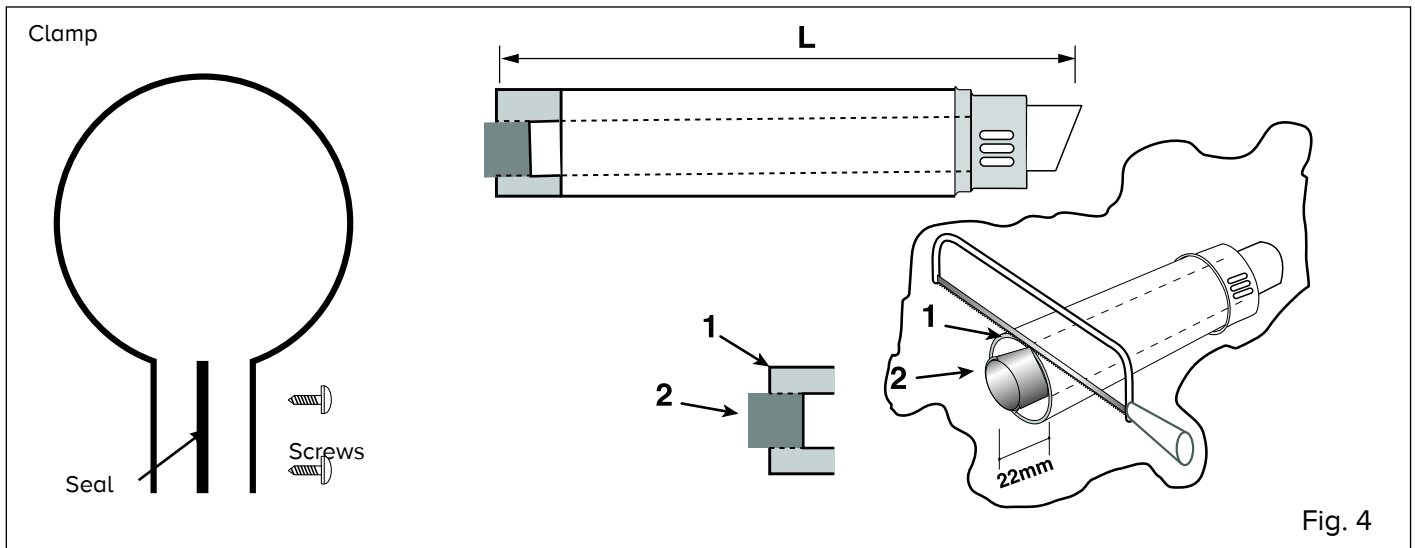
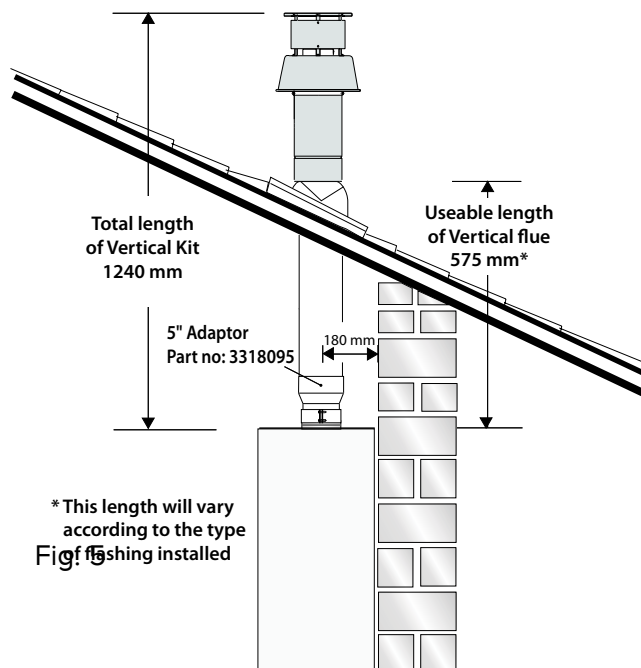

Fig. 4

## Fitting the 5" Flue

(Ø 80 / 125 Horizontal/vertical)



Once the boiler has been positioned on the wall, it is necessary to insert the Ø80/125 adaptor (Fig. 5) for both horizontal and vertical flue runs into the boiler flue socket (not supplied with flue kit - Part No 3318095).

Push the adaptor onto the boiler's flue connection, grease the seals then add extensions or elbows as required, secure the adaptor, using the clamp and screws provided.

To fit extensions or elbows it is first necessary to ensure that the lip seal is fitted correctly into the inner flue, once verified, it is simply necessary to push them together, no clamps are necessary to secure the flue components.

Before proceeding to fit the flue, ensure that the maximum flue length has not been exceeded (See the tables) and that all elbows and bends have been taken into consideration, for each additional 90° elbow 1 metre must be subtracted from the total flue length, and for each 45° 0.5 metres must be subtracted from the total flue length (the height of the vertical adaptor and a 45° bend can be seen in Fig.6 and a 90° bend in Fig. 7).

Note: DO NOT cut the vertical flue kit.

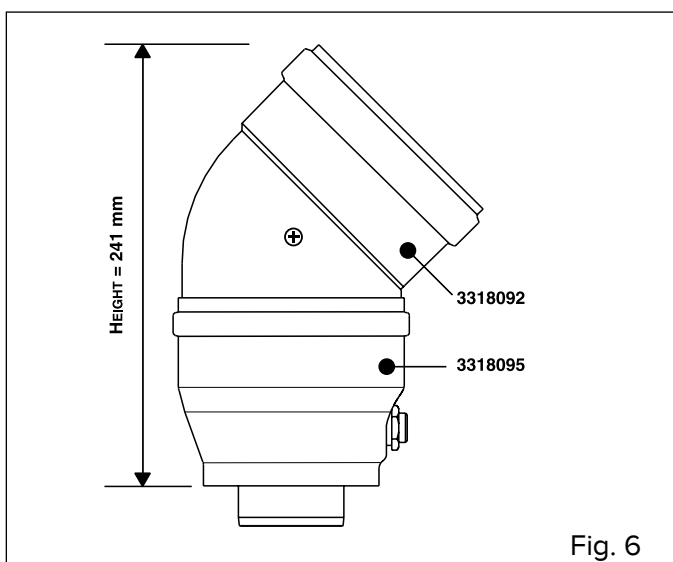

Fig. 6

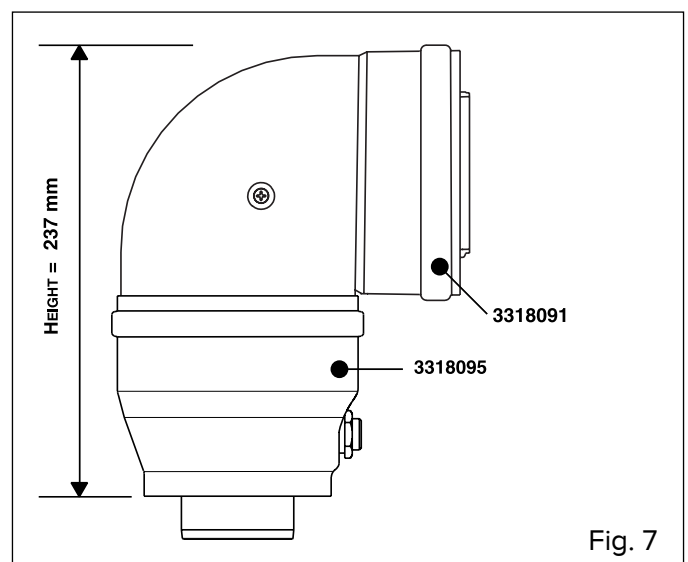

Fig. 7

## Fitting the Coaxial Flue (Ø 60 / 100 Vertical)

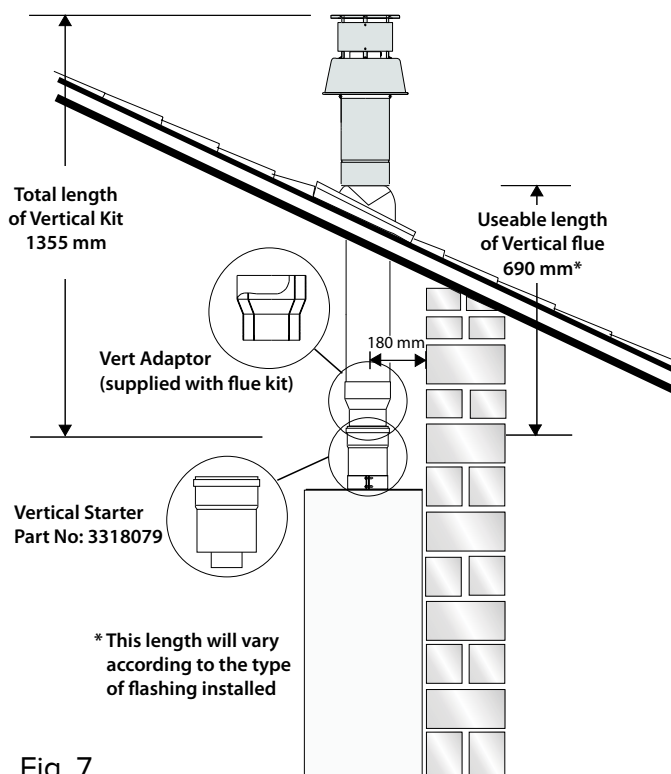

Fig. 7

Note: See table for maximum and minimum flue runs.

Contents:

1x Conical Adaptor (60/100mm)

1x Vertical Flue Kit (80/125mm)

The vertical flue kit is supplied with a specially designed weather proof terminal fitted, it can be used either with a flat roof or a pitched roof.

The Vertical flue kits useable lengths with the pitched roof flashings are indicated in Fig. 7.

Before proceeding to fit the flue, ensure that the maximum flue length has not been exceeded (See the tables) and that all elbows and bends have been taken into consideration, for each additional 90° elbow 1 metre must be subtracted from the total flue length, and for each 45° 0.5 metres must be subtracted from the total flue length (the height of the vertical adaptor and a 45° bend can be seen in Fig. 8).

Mark the position of the flue hole in the ceiling and/or roof (see Fig. 7 for distance from wall to the centre of the flue).

Cut a 130mm diameter hole through the ceiling and/or roof and fit the flashing plate to the roof.

DO NOT cut the vertical flue kit.

To connect the vertical flue kit directly to the boiler, place the vertical starter kit (Part No. 3318079) (see Fig. 7) onto the exhaust manifold and secure with the clamp, fit the vertical adaptor onto the vertical starter kit (note: there is no need to use a clamp to secure this as it is a push fit connection), the vertical flue kit must then be inserted through the roof flashing, this will ensure that the correct clearance above the roof is provided as the terminal is a fixed height.

Should extensions be required, they are available in 1 metre (Part No. 3318077), 500mm (Part No. 3318078) and they must be connected directly to the vertical starter kit before connecting the adaptor to allow the vertical flue kit to be fitted. In the event that extension pieces need to be shortened, they must only be cut at the male end and it must be ensured that the inner and outer flue remain flush.

When utilising the vertical flue system, action must be taken to ensure that the flue is supported adequately to prevent the weight being transferred to the appliance flue connection by using 1 flue bracket per extension.

When the flue passes through a ceiling or wooden floor, there must be an air gap of 25mm between any part of the flue system and any combustible material. The use of a ceiling plate will facilitate this. Also when the flue passes from one room to another a fire stop must be fitted to prevent the passage of smoke or fire, irrespective of the structural material through which the flue passes.

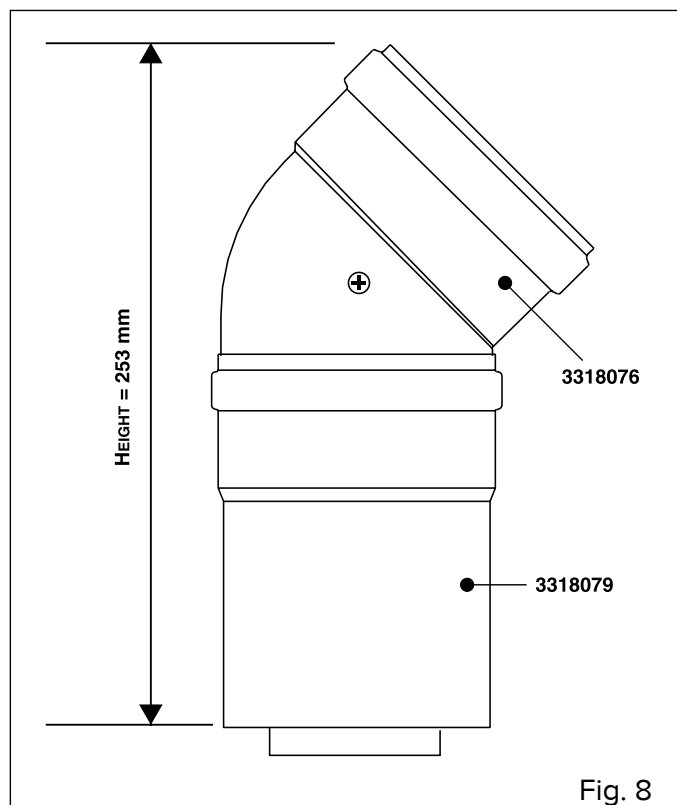
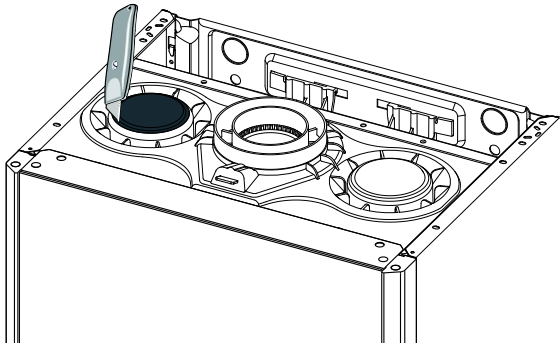

Fig. 8

## Fitting the Twin Pipe (Ø80 / 80)



Note: See table for maximum and minimum flue runs.

Where it is not possible to terminate the flue within the distance permitted for coaxial flues, the twin flue pipe can be used by fitting a special adaptor to the flue connector and using the aperture for the air intake located on top of the combustion chamber.

Always ensure that the flue is adequately supported, using one flue bracket per extension and avoiding low points. (ARISTON supply suitable clamps as Part No. 3318015).

To utilise the air intake it is necessary to:

- 1) Remove the top of the air intake by cutting it with a suitable knife.
- 2) Insert the header on the tube or the elbow up until the lower stop (you do not have to use the washer).
- 3) Insert the elbow/header in the boiler air intake hole and fasten it with screws.

The twin flue pipes can be fitted with or without additional elbows and need no clamps, simply ensure that the lip seal is inserted in the female end of the flue pipe and push the extension piece fully into the previous section of flue pipe or elbow, check that the lip seal is not dislodged when assembling the flue (greasing the seal will aid assembly).

Twin pipe can also be converted back to Coaxial flue to enable vertical termination with a coaxial kit by using the pipe bridge (Twin - Coaxial Adaptor - Part No. 3318089). When running the twin flue pipe vertically.

It is not possible to terminate concentrically horizontally. Termination is only possible with separate air and exhaust terminals.

When siting the twin flue pipe, the air intake and exhaust terminals must terminate on the same wall, the centres of the terminals must be a minimum of 280 mm apart and the air intake must not be sited above the exhaust terminal (refer to Fig. 10). The air intake pipe can be run horizontally, however, the terminal and the final 1 metre of flue must be installed either horizontally or with a slight fall away from the boiler to avoid rain ingress.

It is also strongly recommended that the air intake pipe run be constructed of insulated pipe to prevent condense forming on the outside of the tube.

Ensure the exhaust tube has a minimum fall back to the boiler of 1° / metre (1° = 17.5mm/metre)

The maximum permissible flue length for twin flue is dependent on the type of run used (see table on page 24).

For further information relating to flue runs not illustrated, please contact the **Technical Department on 0333 240 7777**.

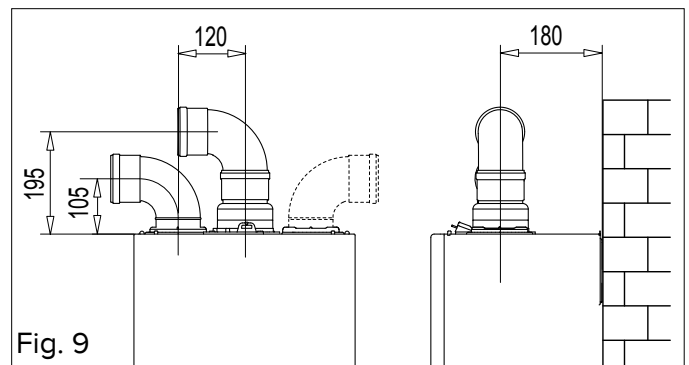

For coaxial systems, the maximum development value, mentioned in the table below also takes into account an elbow. For twin flue systems the maximum development value, mentioned in the table includes the exhaust gas/air intake terminal.

Twin flue systems outlets should respect the following instructions:

- 1- Use the same ø 80 mm flue pipes for the air intakes and exhaust gas ducts.
- 2- If you need to insert elbows in the air intake and exhaust gas ducts, you should consider for each one the equivalent length to be included in the calculation of developed length.
- 3- The exhaust gas duct should jut above the roof by at least 0.5 m.
- 4- The intake and exhaust gas ducts in Type C13 + C53 must be installed on the same wall, or where the exhaust is vertical and the air intake horizontal, the terminals must be on the same side of the building.

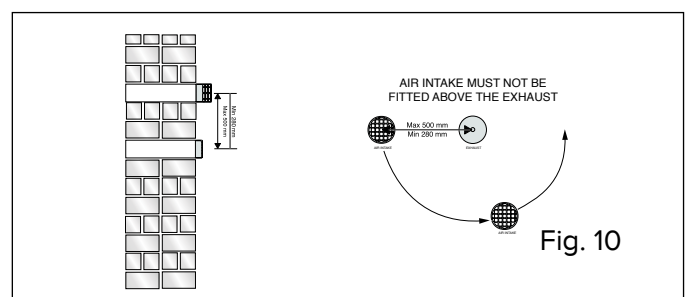

Table of flue gas exhaust duct lengths

FLUE TYPE		Maximum Extension Exhaust-air (m)				Diameter of pipe (mm)
		E-COMBI ONE		E-SYSTEM ONE		
		24	30	24	30	
Coaxial System	C13 C33 C43	8	7	8	7	ø 60/100
	C13 C33 C43	33	24	33	24	ø 80/125
		S1 = S2				ø 80/80
Twin-pipe System	C13	24/24	26/26	24/24	26/26	
	C33	48/48	40/40	40/40	32/32	
	C43	24/24	26/26	24/24	26/26	
	C53	S1 + S2		S1 + S2		
		60	50	60	50	ø 80/80

S1 = Air intake S2 = Flue gas exhaust

S1 = S2 - Air intake and flue gas exhaust equal lengths

S1 + S2 - Air intake and flue gas exhaust unequal lengths

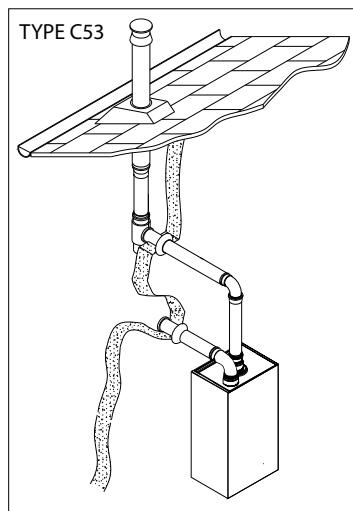
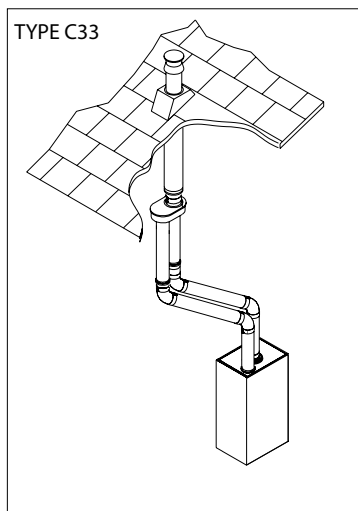
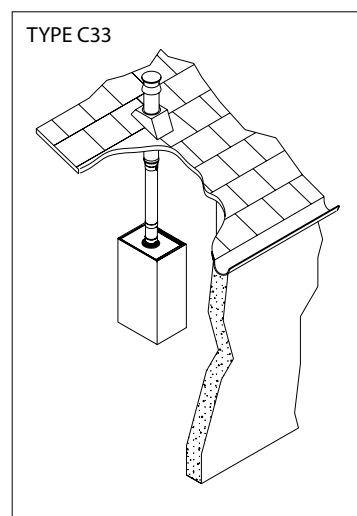
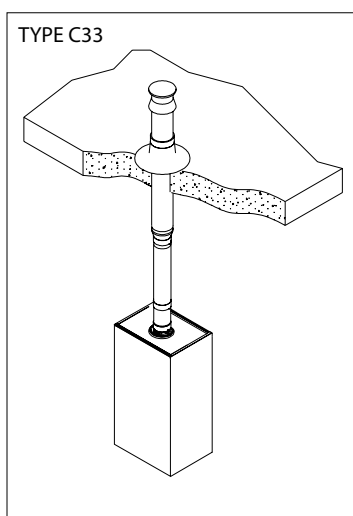
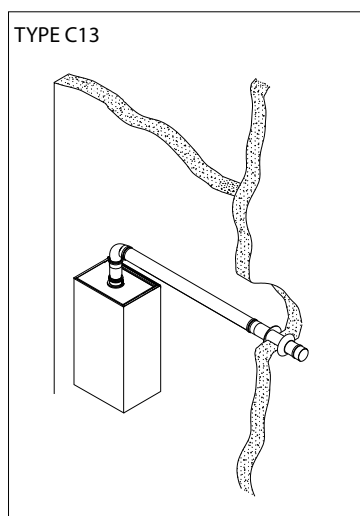

## WARNING!



**BEFORE PERFORMING ANY WORK ON THE BOILER, FIRST DISCONNECT IT FROM THE ELECTRICAL POWER SUPPLY USING THE EXTERNAL BIPOLAR SWITCH AND REMOVE THE FUSE.**

### Electrical connections

For increased safety, ask a qualified technician to perform a thorough check of the electrical system.

The manufacturer is not responsible for any damage caused by the lack of a suitable earthing system or by the malfunctioning of the electricity mains supply.

Make sure that the system is able to withstand the maximum power absorbed by the boiler (this is indicated on the appliance data plate). Check that the section of the wires is suitable and is not less 0,75 mm<sup>2</sup>

The appliance must be connected to an efficient earthing system if it is to operate correctly.

The power supply cable must be connected to a 230V-50Hz network, where the L-N poles and the earth connection are all respected.

Important!

In the event that the power supply cable must be changed, replace it with one with the same specifications.

### Power supply cable

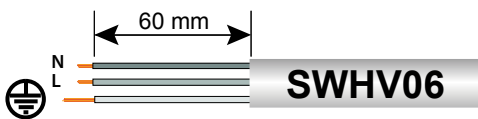

### Important!



The appliance is supplied with a fly-lead already connected, this must be connected to a 240V supply fused at 3 Amp and must facilitate completed electrical isolation of the appliance, by use of a fused double pole isolator having a contact separation of at least 3mm in all poles or alternatively by means of a 3A fused three pin plug and unswitched shuttered socket outlet both complying with BS1363.

The use of multiplugs, extension leads or adaptors is strictly prohibited.

It is strictly forbidden to use the piping from the hydraulic, heating and gas systems for the appliance earthing connection. The boiler is not protected against the effects caused by lightning. If the mains fuses need to be replaced, use 2A rapid fuses.

### Peripheral unit connection

To access peripheral unit connections carry out the following steps:

- Disconnect the boiler from the power supply
- Remove the casing
- Rotate the control panel while pulling it forwards
- Unhook the two clips "a", rotate the cover "b" to have access to the peripheral connections
- Unscrew the two screws "c" and remove the cover "d" of the instrument panel to have access to the main P.C.B.

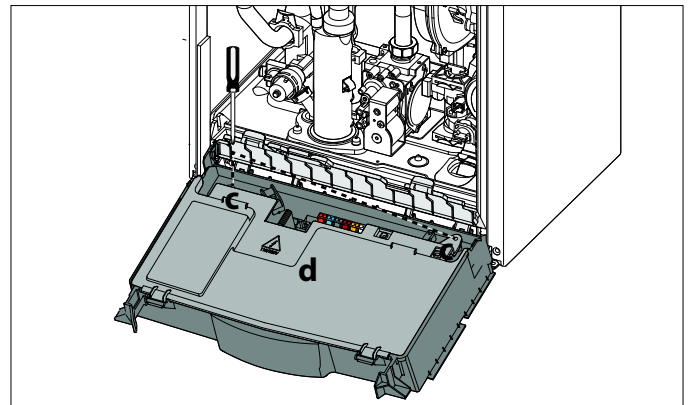
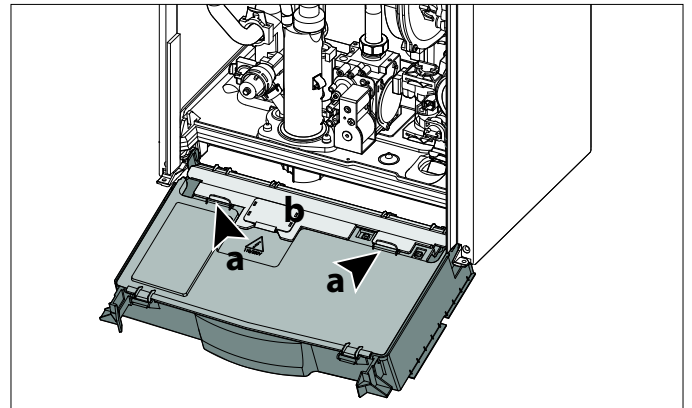

Peripheral connections:

**BUS** = Remote control connection

**FLOOR/TA2** = the underfloor heating thermostat or the room thermostat 2 (selected via parameter 223)

**SE** = the external sensor.

**SOL** = Solar temperature probe

**TA1** = the room thermostat 1

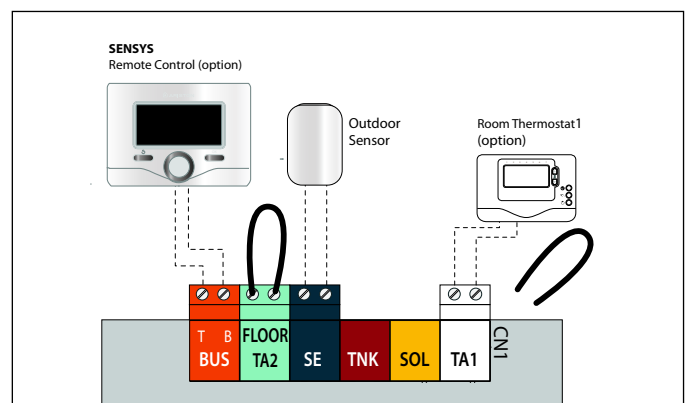

**Room Thermostat / Remote Clock Connection**

To connect a room thermostat, it is necessary to:

1. Open the control panel
2. Loosen the cable clamp using a screwdriver and insert the wires leading from the room thermostat
3. Connect the wires to the terminals as indicated in the figure below, removing the link
4. If a remote time clock is to be fitted, using a volt free switching time clock connect the switching wires from the time clock following points 1- 3 above
5. If using an external time clock and room thermostat, these must be connected in series as shown in diagram C,
6. Ensure that they are well connected and not subject to stress when the control panel is closed

DO NOT CONNECT 240V TO ANY PERIPHERAL CONNECTIONS

**Outdoor sensor connection**

- Introduce the outdoor sensor wires
- Loosen the cable clamp using a screwdriver and insert the wires leading from the outdoor sensor one at a time.
- Connect the wires to the terminals as indicated in the figure below;
- Make sure that they are well connected and that they are not subject to stress when the control panel lid is opened or closed;
- Close the flap again, then replace the control panel cover and the front casing.
- Refer to page 40 for setting the parameters when using the outdoor sensor.

**Outdoor Sensor**

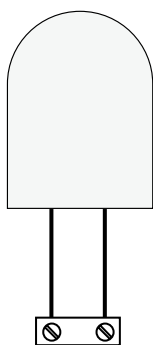

Connector SE on PCB (see p.25)

**NOTE:** WHEN CONNECTING THE BOILER TO EXTERNAL CONTROLS, DO NOT RUN **240V** CABLES AND CABLES FOR SWITCHING CIRCUITS (WHICH ARE LOW VOLTAGE) TOGETHER, USE SEPERATE CABLES TO PREVENT INDUCED VOLTAGE ON THE LOW VOLTAGE CIRCUITS.

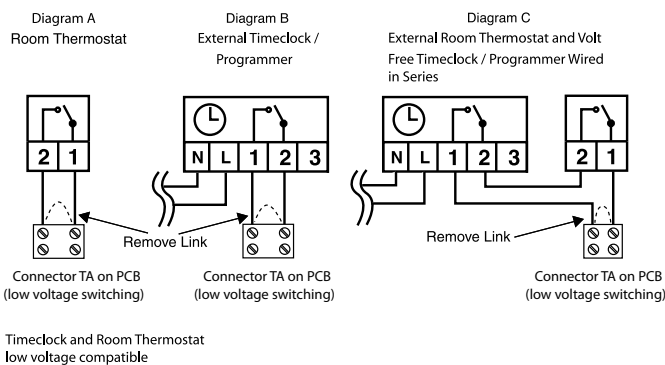

**Cylinder connection (E-SYSTEM ONE)**

The boiler can be connected to a central heating system that uses two zone valves to allow connection to an indirect storage cylinder.

There are two wiring diagrams shown, one for the connection to an Unvented Cylinder and one for connection to an open vented cylinder.

In both cases the boiler connection is shown as TA1.

When connecting the boiler to an external cylinder do not run 240V cables and the cables for the TA1 together, use separate cables to prevent induced voltage on the low voltage switching circuit.

**NOTE:** THE USE OF A 'Y' PLAN SYSTEM IS NOT POSSIBLE WITH THE E-SYSTEM ONE BOILER DUE TO THE LOW VOLTAGE SWITCHING OF THE APPLIANCE UNLESS SUITABLE RELAY CONTROLS ARE USED.

**Important!!**

Ensure that a balancing valve is fitted on the cylinder return and balanced correctly at commissioning stage.

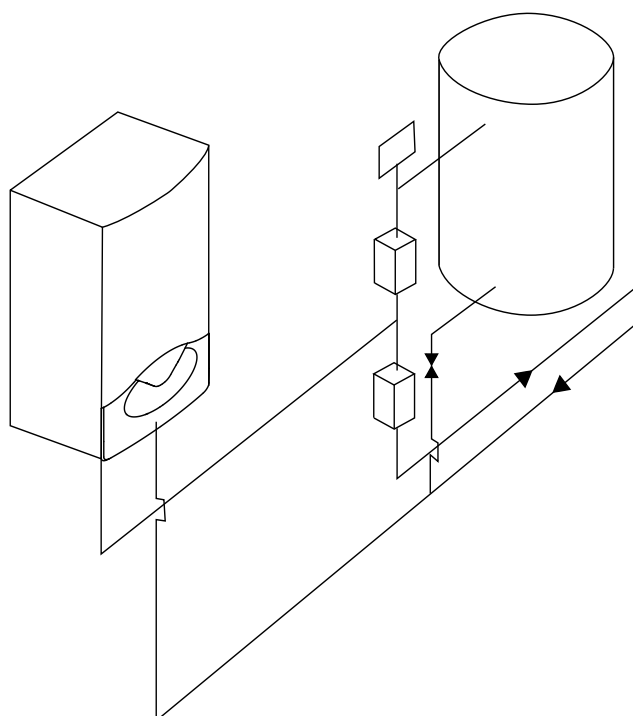

# INSTALLATION

## Electrical diagram

For increased safety, ask a qualified technician to perform a thorough check of the electrical system.

The manufacturer is not responsible for any damage caused by the lack of a suitable earthing system or by the malfunctioning of the electricity mains supply.

**E-COMBI ONE**

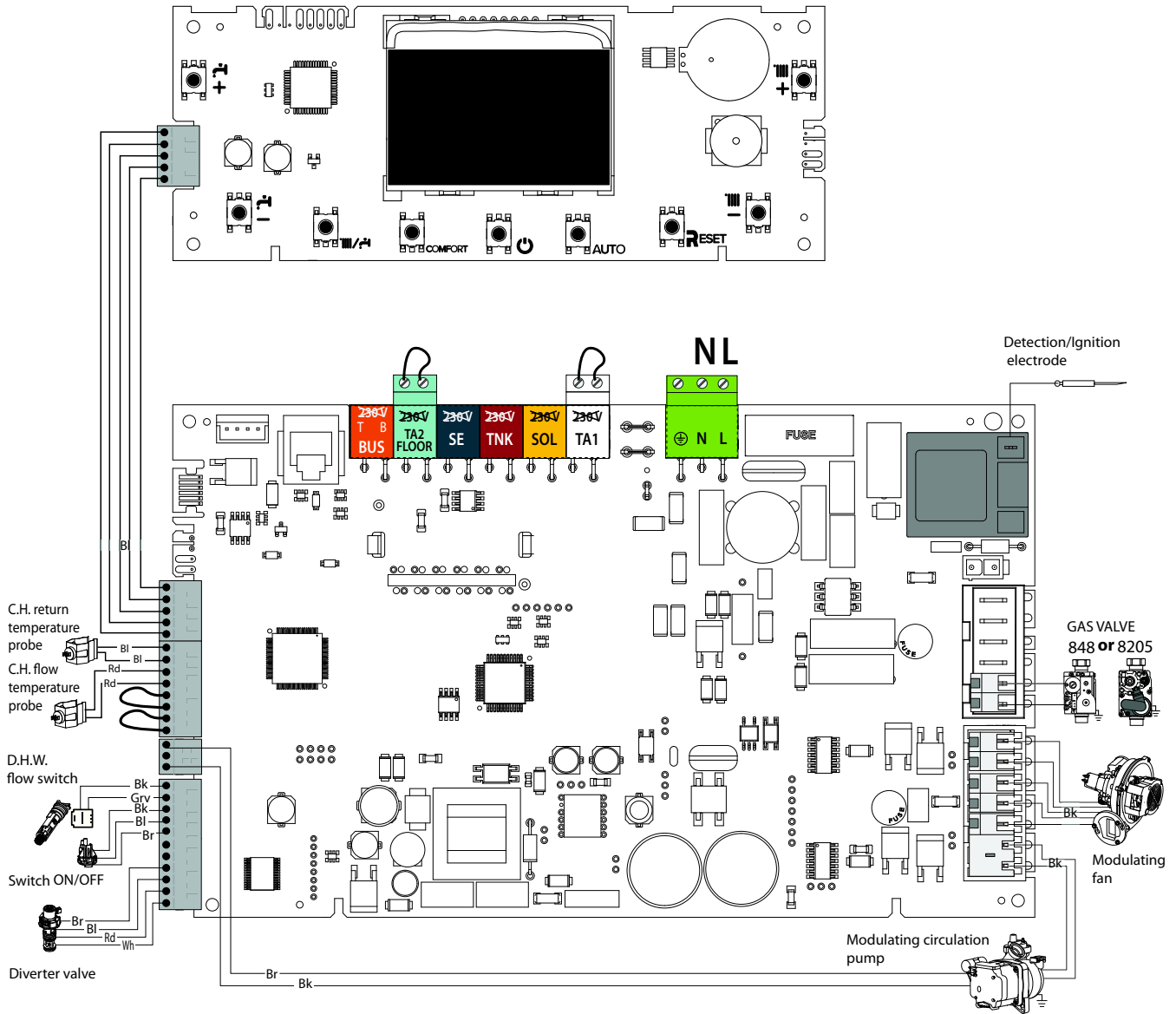

E-SYSTEM ONE

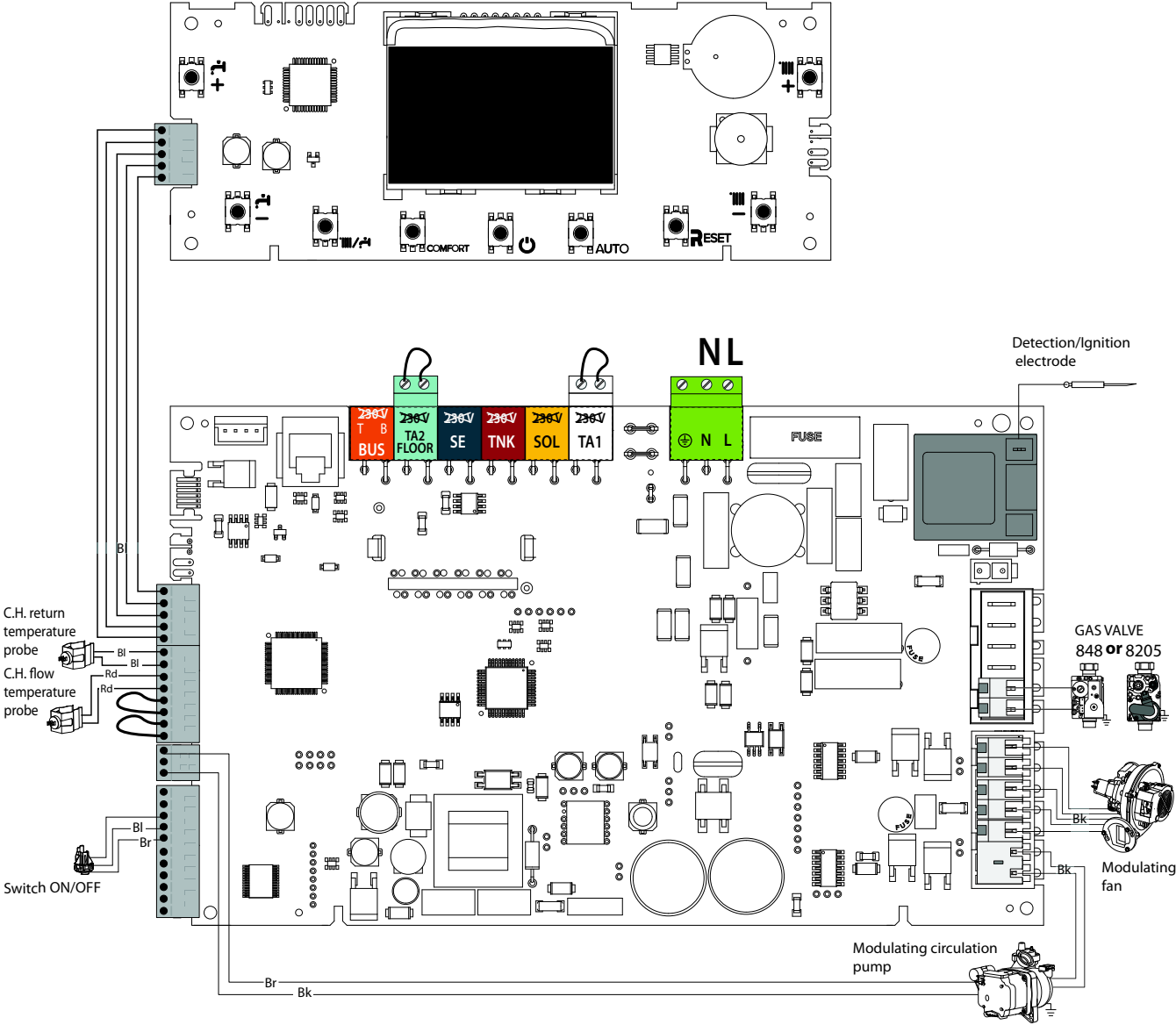

S plan wiring diagram.

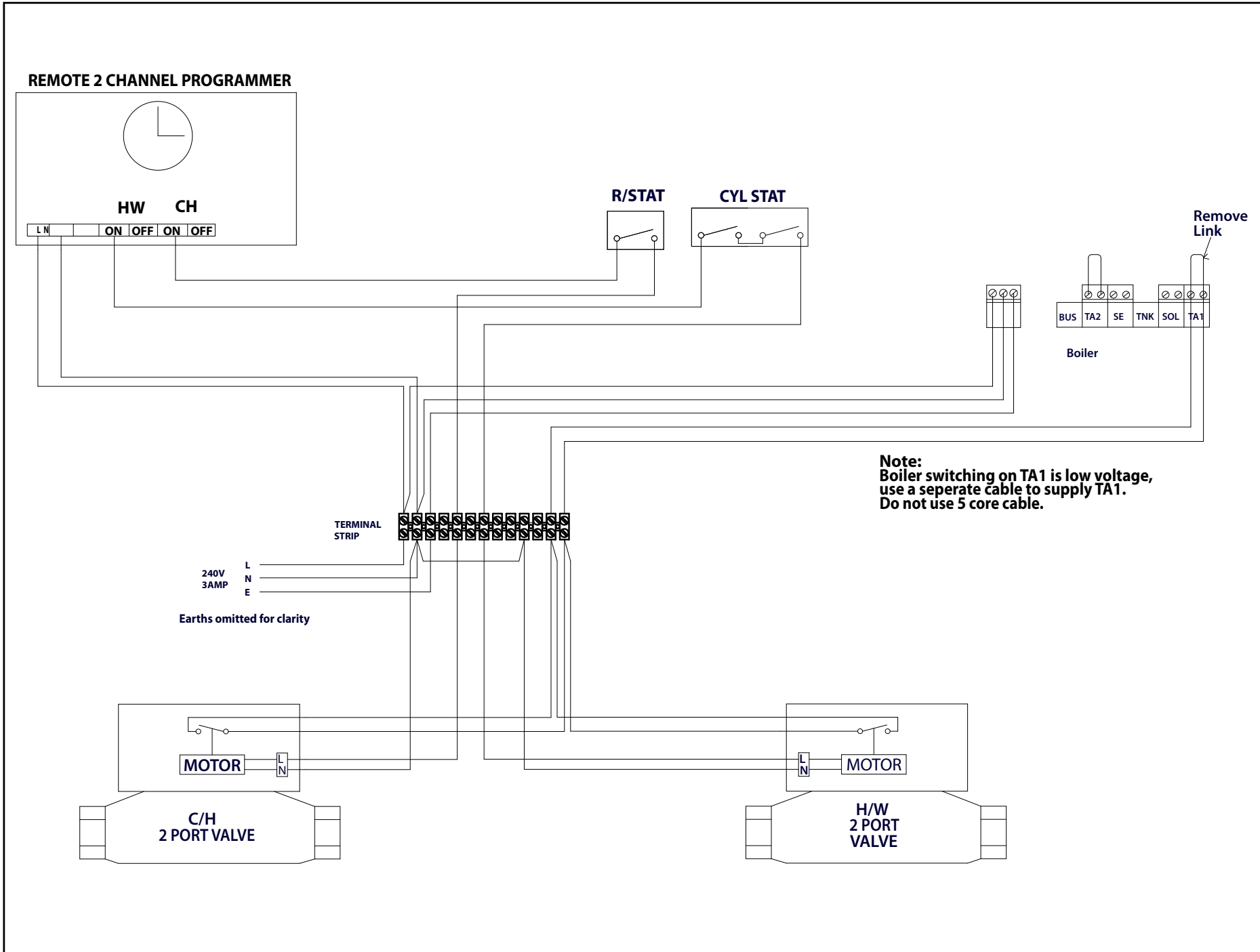

S plan wiring diagram using an outside sensor.

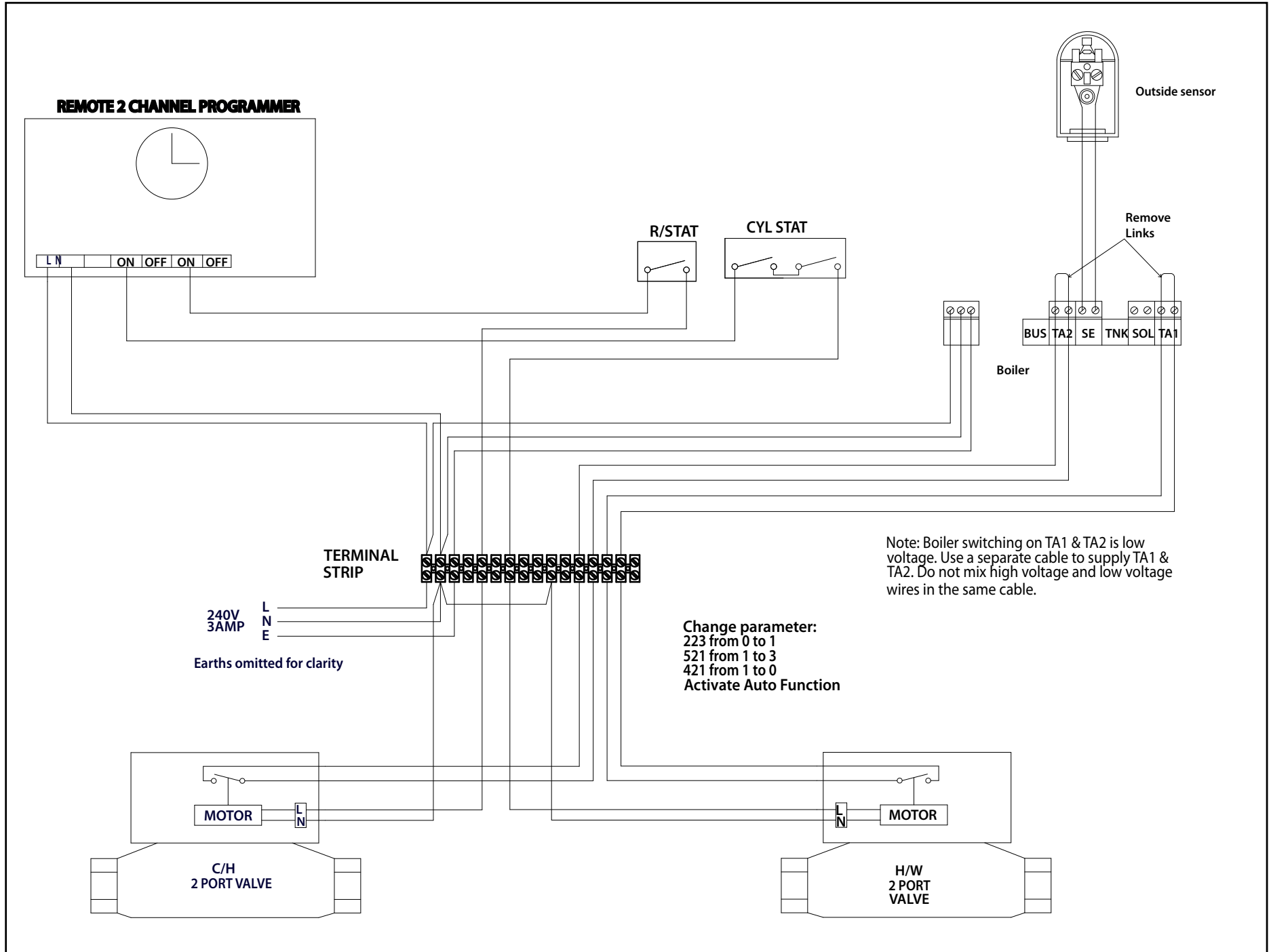

### Initial preparation

Ariston Thermo UK Ltd support the benchmark initiative. On pages 77 and 78 of this manual the Benchmark Commissioning Checklist and Service interval Record can be found. It is important that this is completed in the presence of your customer, they are shown how to use it, and it is signed by them. Please instruct your customer that they must have this manual with them whenever they contact a service engineer or us.

Preliminary electrical system checks to ensure electrical safety must be carried out by a competent person i.e. polarity, earth continuity, resistance to earth and short circuit.

### Electricity supply

- Check that the voltage and frequency of the electricity supply correspond to the data shown on the boiler data plate;
- Make sure that the earthing connection is efficient.

### Filling the Heating System:

#### ATTENTION!!

#### CONNECT THE PIPE OF CONDENSATE DISCHARGE BEFORE REFILLING AND THE DE-AERATION OF THE HEATING CIRCUIT.

Remove the front casing panel and lower the control panel as described on page 15.

Open the central heating flow and return cocks supplied with the connection kit;

Open the manual air vent positioned at the side of the primary exchanger (2). The valve is already connected to a discharge pipe related to the condensate trap.

Close all air release valves on the central heating system;

Gradually open the valves at the filling point (filling loop) until water is heard to flow, do not open fully;

Open each air release tap starting with the lowest point and close them only when clear water free of air is visible;

Continue filling the system until at least 1.5 bar registers on the pressure gauge;

Inspect the system for water tightness and remedy any leaks discovered.

#### IMPORTANT!

**MANUALLY VENT THE HEAT EXCHANGER AT THE MANUAL AIR VENT. FAILURE TO VENT ADEQUATELY MAY DAMAGE THE HEAT EXCHANGER (PAGE 9, LEGEND 2).**

### Filling of the DHW System:

Close all hot water draw off taps;

Open the cold water inlet cock supplied with the connection kit; Slowly open each draw off tap and close them only when clear water, free of bubbles, is visible.

### Gas Supply:

Inspect the entire installation including the gas meter and test for tightness. The entire installation should be in accordance with the relevant standards. In GB this is BS 6891 and in IE this is the current edition of I.S.813.

The connection on the the appliance is a 15mm (22mm on 38Kw) nut and olive located at the rear of the gas service cock.

If the gas supply serves other appliances, ensure that an adequate supply is available both to the boiler and the other appliances when they are in use at the same time.

Pipe work must be of an adequate size. The final pipe size must not be smaller than the appliance inlet size.

Open the gas cock (supplied with the connection kit) to the appliance and check the gas connection on the appliance for leaks.

### Water Treatment:

The boiler is equipped with a stainless steel heat exchanger. The detailed recommendations for water treatment are given in BS 7593 (Treatment of water in domestic hot water central heating systems); the following notes are given for general guidance;

If the boiler is installed on an existing system, any unsuitable additives must be removed;

Under no circumstances should the boiler be fired before the system has been thoroughly flushed; the flushing procedure must be in line with BS7593.

Firstly fill the central heating system with the power off, and flush through cold, fill the central heating system again, adding a flushing detergent, run the boiler on central heating until it reaches its operating temperature and flush the system, refill the system with a suitable corrosion inhibitor,

NOTE: FAILURE TO CARRY OUT THE FLUSHING PROCEDURE WILL RESULT IN THE WARRANTY BECOMING VOID.



# FIRST IGNITION OPERATION

Date .....

Installer .....

1. Check the electrical supply.

Complete .....



2. Check the type of gas and change the gas if necessary.

Complete .....



3. Check the gas tightness.

Complete .....

4. Measure the gas inlet.

Complete .....

5. Check the Flue

Complete .....



6. Fill the installation.

Complete .....

7. Check the hydraulic water tightness.

Complete .....



8. Ensure the pump is operating.

Complete .....



9. Purge the air with once pressing on ESC button during 5 sec.

Complete .....

10. Set the heating power.

Complete .....



11. Balance the central heating circuit.

Complete .....



12. Check the operation in DHW mode.

Complete .....

13. Adjust DHW flow rate on the boiler (if necessary).

Complete .....



14. Check combustion by pressing the RESET button for 5 sec.

Complete .....



15. Check gas rate.

Complete .....

16. Check the ionisation current.

Complete .....

17. Explain to the end user the working of the boiler.

Complete .....

## Ignition procedure

Press the ON/OFF button on the control panel to switch on the boiler. The display shows:

- the operating mode:

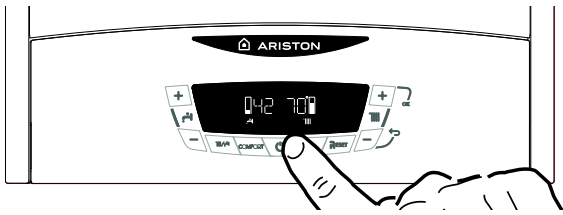

winter



summer



Only heating - E-SYSTEM ONE

- The figures indicate:
  - the flow temperature when no heating requests have been made
  - the flow temperature in central heating mode
  - the temperature of the hot water set in domestic hot water

The carrying out of certain functions is shown:

Deaeration cycle started	
Centrl Heating Post-circulation	
D.H.W. circuit Post-circulation	

## Electricity supply

- Check that the voltage and frequency of the electricity supply correspond to the data shown on the boiler data plate;
- Make sure that the earthing connection is efficient.

## First ignition

1. Make sure that:

- The gas valve is closed;
- The electrical connection has been properly carried out. Make sure that, in any case, the green/yellow earthing wire is connected to an efficient earthing system;
- Use a screwdriver to lift the cap on the automatic air relief valve;
- Switch on the boiler (by pressing the ON/OFF button) and use the MODE button to select the standby mode, where no hot water or heating requests are made.

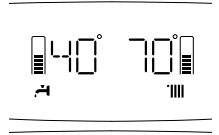

- The boiler starts (automatically) a deaeration cycle lasting about 7 minutes (See below). If you need to stop it press MODE. During the deaeration cycle open the manual air vent (2) on the heat exchanger and close when clear water free of air is visible.
- At the end, check that the system is completely deaerated and, if not, repeat the procedure.
- Bleed the air from the radiators;
- The exhaust duct for combustion products should be suitable and free from any obstructions;
- Any necessary ventilation inlets in the room should be open (type B installation).
- Check whether the condense trap contains water; if not, it must be refilled. If necessary, open the manual air vent on the main exchanger until complete filling.



**N.B.: if the boiler will not be used for long periods, the trap should be filled before the boiler is started up again. It is dangerous not to refill the siphon as fumes may be released into the environment.**

2. Open the gas cock and check the connection seals, including the boiler connection joints, making sure that the meter does not detect any passage of gas. Eliminate any leaks.
3. Start the boiler by selecting the heating or domestic hot water operation using the MODE button.

## Description of Function

### Deaeration cycle

The boiler activates the Deaeration Cycle automatically when the boiler is powered on for the first time or after the error 108 (for approximately 7 minutes).

When this is complete the menu screen will be restored. The cycle may either be repeated, if necessary, or stopped by pressing MODE. Press the MODE button until the normal display screen is restored. **IF THE CYCLE IS STOPPED BE SURE TO MANUALLY VENT THE APPLIANCE.**

**Combustion checking procedure**

The order of operations for this procedure must always be respected.

Refer to Technical Bulletin 143 on Gas Safe Register website for further information on combustion analysis of domestic boilers.

**Operation 1 - Supply pressure check**

Loosen the screw **1** and insert the pressure gauge connection pipe into the pipe tap.

Switch the boiler on at maximum power.

To activate combustion test function:

- Press the mode selector to ensure the icons displayed.
- Press & hold the reset button for 10 seconds. 'TEST' will appear on the screen. Ensure the boiler is on max power by pressing the button **2** .

The supply pressure should correspond to the value established in relation to the type of gas, for which the boiler is designed see Table summarising changes.

**Note:**

The absolute minimum working pressure measured at the inlet test nipple on the gas valve is 17.5 mbar.

**Gas valve 848**

**Gas valve 8205**

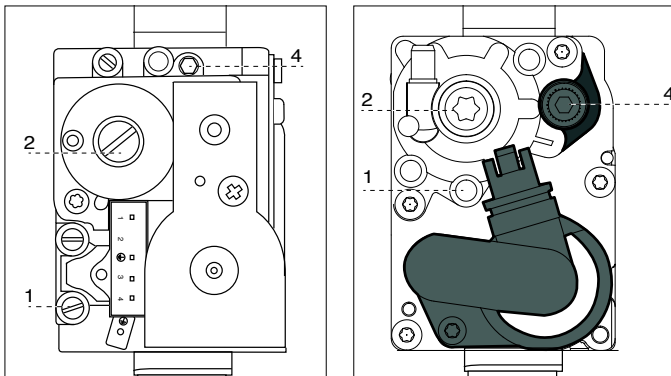

**Operation 2 - Preparing the measuring equipment**

Connect the calibrated flue gas analyser to the left-hand combustion outlet by unscrewing the screw and removing the blanking cover.

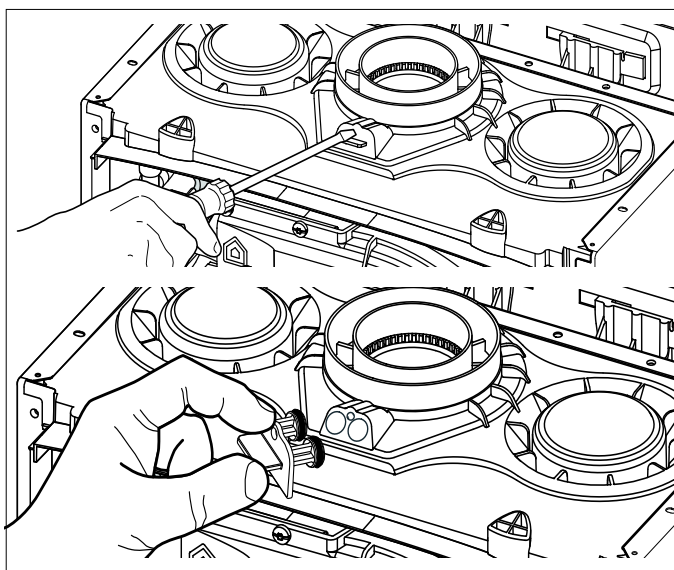

**Operation 3 - Adjusting the CO2 at maximum gas flow rate (domestic hot water)**

Draw off the domestic hot water at the maximum water flow rate (if a combi).

Select the Test function by pressing the RESET button for 10 seconds.

**WARNING! When the cleaning function is activated, the temperature of the water coming out of the boiler may be more than 65°C.**

On the display appear TEST and the icon . The boiler is forced to the maximum heating power.

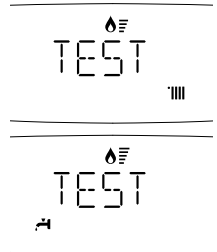

Press the **2** button to forced the boiler at the maximum DHW power. On the display appear the icon .

Wait 1 minute for the boiler to stabilise before carrying out the combustion analyses.

Read the CO2 value (%) and compare it with the values given in the table below

**N.B.:** VALUES WITH THE CASING CLOSED.

	E-COMBI ONE E-SYSTEM ONE	
Gas	CO <sub>2</sub> (%) MAX	CO <sub>2</sub> (%) MIN
G20	8,7% ÷ 9,7%	8,4% ÷ 9,4%
G31	9,5% ÷ 10,5%	
<b>ATTENTION! CO<sub>2</sub>max – CO<sub>2</sub>min &gt; 0,5%</b>		

If the CO2 value (%) read differs from the values given in the table, then adjust the gas valve following the instructions below, otherwise move directly onto operation 4.

**Adjusting the gas valve at maximum gas flow**

Adjust the gas valve by turning setting screw **4** clockwise in increments to reduce the CO2 level (a 1 turn adjusts the CO2 level by approximately 0.2%). Wait 1 minute after each change in setting for the CO2 value to stabilise.

If the value measured corresponds to the value given in the table, max adjustment is complete, otherwise start the setting procedure again.



**N.B.** The Test function is automatically deactivated after 10 minutes or manually by briefly pressing the RESET button.

**Gas valve 848**

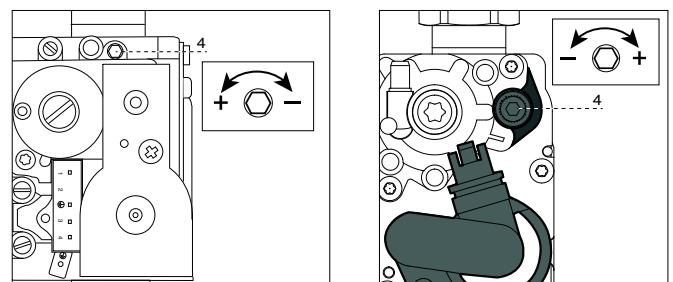
**Gas valve 8205**



## Operation 4 - Checking the CO2 at minimum gas flow

With the Test function active, press the **2** button to select the icon  and . The boiler is forced to the minimum power. Wait 1 minute for the boiler to stabilise before carrying out the combustion analyses.

If the CO2 value (%) read differs by 0.5 % from the value found, then adjust the gas valve following the instructions below, otherwise move directly onto operation 5.

### Adjusting the gas valve to minimum gas flow

Remove cap and adjust screw **2** by turning anti-clockwise in increments to reduce the CO2 level. Wait 1 minute after each adjustment for the CO2 value to stabilise.

**WARNING!** this adjustment is sensitive: a rotation of a 1 turn corresponds to 0.2% of CO2.

If the value measured corresponds to the value given in the table, adjustment is complete, otherwise start the setting procedure again.

**Attention! If the value of the CO2 at the minum power has been changed, it is necessary repet the adjusting at maximum gas flow.**

Gas valve 848

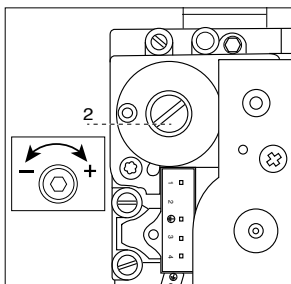

Gas valve 8205

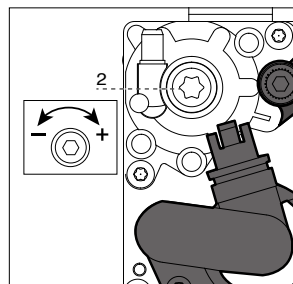

## Operation 5 - Ending the adjustment

Exit cleaning mode by pressing RESET.

Stop the draw-off.

Verify and repair any leaks of gas.

Refit the front panel to the device.

Refit the blanking cover at combustion test point.

menu **2** - Boiler parameters

submenu **3** - parameter **1** Maximum Heating Power adjustment

submenu **2** - parameter **0** Soft light Ignition

submenu **3** - parameter **5** Heating ignition delay

### Maximum Heating Power adjustment

The maximum heating power can be adjusted to between the maximum power allowed by the boiler and the minimum power). The display shows the value between 100% ("100" on the display) and 0% ("0") of this interval.

To check the maximum heating power, access menu 2/sub menu 3/parameter 1, check the value and, if necessary, modify it as indicated in the Gas Regulation table below. (See page 40 for more details).

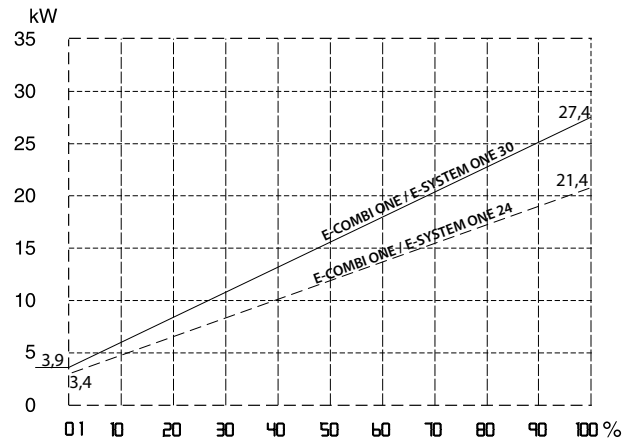

### Checking slow ignition power

The soft light can be adjusted between the maximum power (shown on the display as "100", i.e. 100%) and the minimum power (shown on the display as "1", i.e. 1%).

To check the slow ignition power, access menu 2/sub menu 2/parameter 0.

### Heating ignition delay adjustment

This parameter – menu 2/sub menu 3/parameter 5 - can be used to manually (0) or automatically (1) set the delay time before the subsequent reignition of the burner after it has switched off on reaching the desired temperature in central heating mode.

By selecting manual, it is possible to set the delay in minutes using the successive parameter (menu 2/sub menu 3/parameter 6), to a time between 0 and 7 minutes.

Automatic selection means that the boiler will establish the delay time based on the set-point temperature installation instructions. Ensure the flue gas analyser used is calibrated and set for the gas group the appliance is being adjusted for.

12. Check the appliance for gas leaks using gas leak detection fluid.

13. Affix the label to the appliance that is supplied with the conversion kit.

Table summarising changes

	parameter	E-COMBI ONE			
		E-SYSTEM ONE			
		24		30	
		G20	G31	G20	G31
Lower Wobbe index (15°C, 1013 mbar) ( MJ/m <sup>3</sup> )		45,67	70,69	45,67	70,69
Inlet Gas pressure		20	30-37	20	30-37
Slow ignition	220	64		62	
Maximum C. H.power Adjustable (%)	231	56		60	
Minimum power (%)	233	3		3	
Max CH power (%)	234	75		84	
Max DHW power (%)	232	90		90	
Gas diaphragm (∅)	mm	<b>5,0 (*)</b>	<b>3,6</b>	<b>5,8 (*)</b>	<b>4,0</b>
Gas flow max/min (15°C, 1013 mbar) (nat - m <sup>3</sup> /h) GPL - kg/h)	max D.H.W	2,751	2,020	3,175	2,330
	max C.H	2,328	1,709	2,963	2,175
	min	0,391	0,287	0,455	0,334

(\*) Gas diaphragm integrated in the air/gas mixer  
(NON-REMOVABLE)

**Converting the appliance from Natural gas to LPG**

These appliances are designed to operate with different gas types.

The appliance must only be converted for use with a different gas type by a Gas Safe Registered installer.

To convert the appliance to LPG:

(use these instructions in conjunction with the Instruction sheet supplied with the LPG Kit).

1. Electrically isolate the appliance (fig 1)
2. Turn off the gas supply (fig 2)
3. Remove the outer case, lower the front control panel.

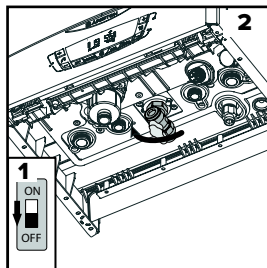
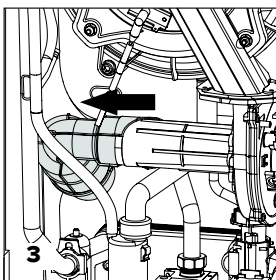

4. Remove the silencer (fig 3)

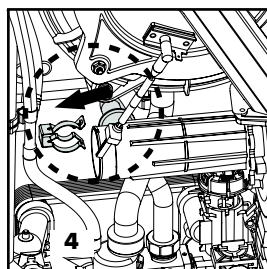

5. Disconnect the gas supply from the venturi assembly (fig 4)
6. Inset the correct diaphragm (depending on the output of the appliance) into the venturi spigot (fig 5)

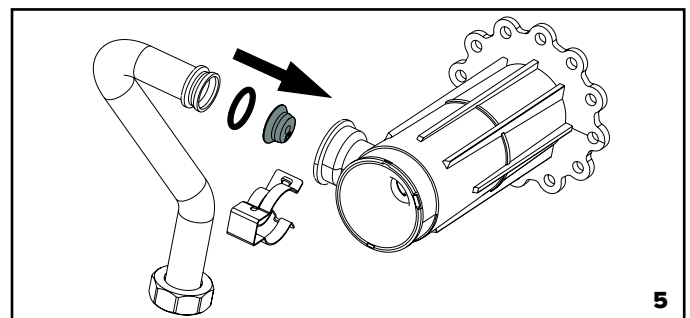

7. Reassemble the gas supply onto the venture assembly (fig 4) and reattach the silencer.
8. Turn on gas supply and test for tightness
9. Purge gas supply
10. Turn the electrical supply on to the appliance.
11. Commission the appliance, check the working pressure is adequate then test and adjust the CO<sup>2</sup> values at maximum and minimum output described in the commissioning section of the appliance installation instructions. Ensure the flue gas analyser used is calibrated and set for the gas group the appliance is being adjusted for.
12. Check the appliance for gas leaks using gas leak detection fluid.
13. Affix the label to the appliance that is supplied with the conversion kit.

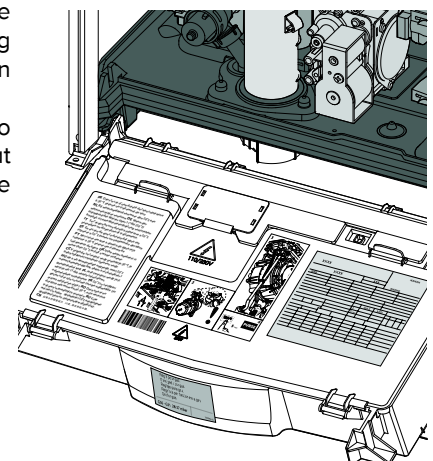

## AUTO function

This is a function which enables the boiler to automatically adapt its operation routine (the temperature of the heating elements) in line with the outdoor conditions, in order to achieve and maintain the requested room temperature conditions.

Depending on the peripheral units connected and the number of zones controlled, the boiler adjusts its flow temperature automatically.

The various corresponding parameters should therefore be set (see adjustments menu).

To activate the function, press the AUTO button.

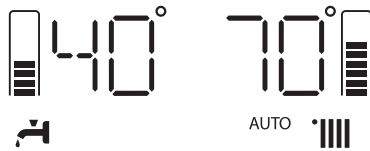

### Example 1:

Single zone system (high-temperature) with on/off room Thermostat:

In this case the following parameters must be set:

4 21 - Activation of temperature adjustment using sensors  
- Select 1 = Basic temperature adjustment

2 44 - Boost Time (optional)

The wait time for the flow temperature increase in steps of 4°C may be set. The value varies according to the type of system and installation.

If the Boost Time value = 00 the function is not activated.

### Example 2:

Single zone system (high-temperature) with on/off room Thermostat + outdoor sensor:

In this case the following parameters must be set:

4 21 - Activation of temperature adjustment using sensors  
- Select 3 = outdoor sensor only

4 22 - Temperature adjustment curve selection

- Select the relevant curve according to the type of system, installation, heat insulation used in the building, etc.

4 23 - Perform a parallel curve shift if necessary, increasing or decreasing the set-point temperature (this may also be modified by the user, using the heating temperature adjustment knob, which, with the Auto function activated, is used to shift the curve in a parallel manner).

### Example 3:

Single zone system (high-temperature) with Sensys controller + outdoor sensor

In this case the following parameters must be set:

4 21 - Activation of temperature adjustment using sensors  
- select 4 = outdoor sensor + room sensor

4 22 - Temperature adjustment curve selection

- Select the relevant curve according to the type of system, installation, heat insulation used in the building, etc

4 23 - Perform a parallel curve shift if necessary, increasing or decreasing the set-point temperature. (This may also be changed by the user by the buttons 8 which, with the Auto function activated, is used to shift the curve in a parallel manner.)

4 24 - Influence of room sensor

- used to adjust the influence the room temperature has on the calculation of the set-point flow temperature (20 = maximum, 0 = minimum).

**Note: See page 40 for details on accessing menus.**

**Boiler protection devices**

The boiler is protected from malfunctioning by means of internal checks performed by the electronic microprocessor P.C.B., which stops the boiler from operating if necessary.

In the event of the boiler being shut off in this manner, a code appears on the display which refers to the type of shut-off and the reason behind it.

There are two types of shut-off:

**Safety shut-off**

This type of error is “volatile”, which means that the boiler starts up again automatically as soon as the problem which caused the shut-off is removed; the error is indicated by the «ERROR» symbol which appears on the display and the error code.

In fact, soon as the cause of the shut-off disappears, the boiler starts up again and continues to operate normally.

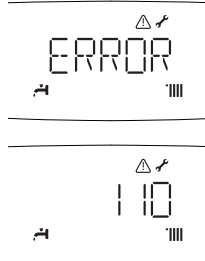

In the event of error **108 - Shut-off due to insufficient water pressure** inside the heating circuit - the boiler will perform a safety shut-off.

You can increase the pressure by filling the heating circuit.

In this case or if the re-balancing request is performed on a frequent basis, switch the boiler off, turn the external electric switch to the OFF position, shut off the gas cock and contact a qualified technician to check for any leaks of water.

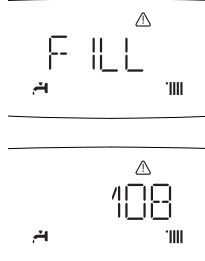

**Shutdown**

This type of error is “non-volatile”, which means that it is not removed automatically. To restore normal operation press the **Reset** button on the control panel.

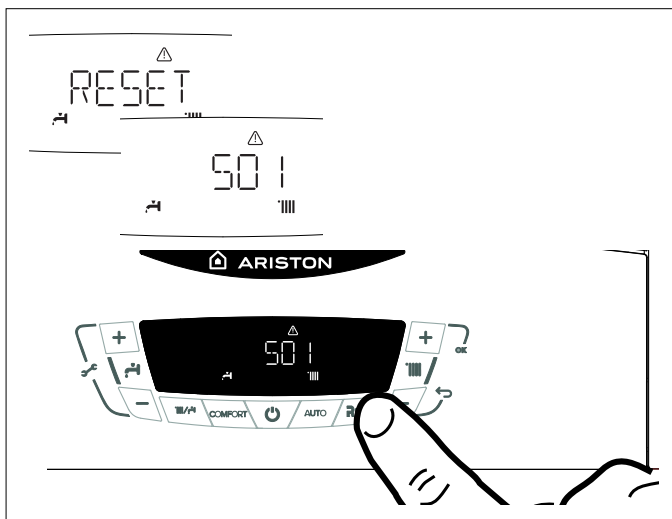

**Important**

If this shutdown occurs frequently, contact an authorised Technical Service Centre for assistance. For safety reasons, the boiler will permit a maximum of 5 resets in 15 minutes (5 presses of the RESET button); at the 6th attempt within this 15-minute period the boiler will shut down and may only be operated again after the electricity supply has been disconnected. If the shutdown is occasional or an isolated event, this is not a problem.

**Malfunction warning**

This warning is shown by the display in the following format: 5 P1 = FIRST IGNITION ATTEMPT UNSUCCESSFUL the first figure indicating the operational assembly is followed by a P (warning) and the code relating to the specific warning.

The first figure of the error code (e.g. 1 01) indicates within which operational assembly the error occurred.

- 1 - Primary Circuit
- 2 - Domestic Hot Water Circuit
- 3 - Internal Electronic Part
- 4 - External Electronic Part
- 5 - Ignition and Detection
- 6 - Air inlet - flue gas outlet
- 7 - Multi-zone Heating

**Table summarising error codes**

Central Heating circuit	
Display	Description
1 01	Overheat
1 03	Insufficient circulation
1 04	
1 05	
1 06	
1 07	
1 08	Insufficient water (request filling)
1 09	System pressure > 3 bar
1 10	C.H. Flow temp. probe circuit open / short circuit
1 12	C.H. Return temp. probe circuit open / short circuit
1 14	External sensor circuit open / short circuit
1 16	Floor Thermostat contact open
1 18	Heating delivery probe problem
1 P1	Insufficient circulation indication
1 P2	
1 P3	
1 P4	
D.H.W. circuit	
2 05	DHW In Probe Open Circuit (Solare temp. probe)
Internal P.C.B.'s	
3 01	EEPROM error
3 02	Communication error
3 03	Main P.C.B. error
3 04	Too many (> 5) resets in 15 minutes
3 05	Main P.C.B. error
3 06	Main P.C.B. error
3 07	Main P.C.B. error
3 P9	Sched.Maintanace-Call Service
External P.C.B.'s	
4 11	Room sensor circuit open or short circuit ZONA 1
4 12	Room sensor circuit open or short circuit ZONA 2
4 13	Room sensor circuit open or short circuit ZONA 3

Ignition and Detecion	
5 01	No flame detected
5 02	Flame detected with gas valve closed
5 04	Flame lift
5 P1	1st Ignition Failed
5 P2	2nd Ignition Failed
5 P3	Flame cut-off
Air Inlet / Flue gas outlet	
6 10	Overheat (Main heat exchanger)
6 12	Insufficient fan speed
Multi-zone Heating (Heating Zone Modules - optional)	
7 01	Zone 1 send sensor defective
7 02	Zone 2 send sensor defective
7 03	Zone 3 send sensor defective
7 11	Zone 1 return sensor defective
7 12	Zone 2 return sensor defective
7 13	Zone 3 return sensor defective
7 22	Zone 2 overheating
7 23	Zone 3 overheating
7 50	All Heating Zones locked

### Anti-frost Device.

The anti-frost function acts on the central heating flow temperature probe, independently from other regulations, when the electrical supply is turned on.

If the primary circuit temperature is between 3°C and 8°C the pump will run (with the diverter valve switching between central heating and hot water every 1 minute) until the temperature reaches > 9°C.

If the flow temperature remains between 3°C and 8°C the pump will continue to run for a maximum of 20 minutes unless a temperature above > 9°C is detected in the central heating flow, after this the the burner will fire (heating position) until a temperature of > 30°C is detected.

If the central heating flow temperature is < 3°C, the burner will fire (heating position) at minimum power until the temperature reaches > 35°C, the burner will go out.

If lockout is caused by overheat the burner will not fire but the pump will continue to run (heating position).

The anti-frost device activates only when (with the boiler operating correctly):

- the system pressure is correct;
- the boiler is electrically powered;
- there is a supply of gas.

## Accessing the settings - adjustment - problem identification menus

The boiler can be used to manage the heating and domestic hot water production system in its entirety.

Navigation within the menus enables the boiler system + connected peripheral units to be customised, optimising operation for maximum comfort and maximum saving. It also provides important information relating to the efficient operation of the boiler.

Before access to the menus, the display show some "quick settings" to have direct access to the parameters.

To see all available parameters and menu access to view FULL MENU.

<b>GAS</b> - Direct access to the parameters: └─ 220 - 231- 232- 233 - 234 - 270
<b>SET</b> - Direct access to the parameters: └─ 220 - 231- 223 - 245 - 246
<b>PCB</b> - Direct access to the parameters: └─ 220 - 228 - 229 - 231- 232- 233 - 234 - 247 - 250 - 253
<b>VIS</b> - Direct access to the parameters: └─ 821 - 822 - 824 - 825 - 827 - 830 - 831 - 832 - 833- 840 - 835
<b>ZONE</b> - Direct access to the parameters: └─ 402 - 502 - 602 - 420 - 520 - 620 -434 - 534 - 634 - 830
<b>FULL MENU</b> - see table on following pages
<ul style="list-style-type: none"> <li>0 NETWORK                     <ul style="list-style-type: none"> <li>0 4 User Interface</li> </ul> </li> <li>2 Boiler Parameter                     <ul style="list-style-type: none"> <li>2 0 General setting</li> <li>2 2 Boiler parameter</li> <li>2 2 General setting</li> <li>2 3 C.H. Parameters - Part 1</li> <li>2 4 C.H. Parameters - Part 2</li> <li>2 5 Domestic Hot Water</li> <li>2 6 Boiler manual settings</li> <li>2 7 Test &amp; Utilities</li> <li>2 8 Menü 2 Reset to factory setting</li> </ul> </li> <li>4 Zone 1 Parameters                     <ul style="list-style-type: none"> <li>4 0 Set-point Zone1</li> <li>4 2 Zone 1 Setting</li> <li>4 3 Diagnostics</li> </ul> </li> <li>5 Parametri Zona 2                     <ul style="list-style-type: none"> <li>5 0 Set-point Zone2</li> <li>5 2 Zone 2 Setting</li> <li>5 3 Diagnostics</li> </ul> </li> <li>6 Parametri Zona 3                     <ul style="list-style-type: none"> <li>6 0 Set-point Zone3</li> <li>6 2 Zone 3 Setting</li> <li>6 3 Diagnostics</li> </ul> </li> <li>8 Service Parameter                     <ul style="list-style-type: none"> <li>8 0 Statistics-1</li> <li>8 1 Statistics-2</li> <li>8 2 Boiler</li> <li>8 3 Boiler Temperature</li> <li>8 4 Solar &amp; Storage</li> <li>8 5 Service</li> <li>8 6 Error History</li> <li>8 7 Free parameter</li> </ul> </li> </ul>

The parameters relating to each individual menu are listed in the following pages.

The various parameters can be accessed and modified using the "+" and "-" buttons, "+" OK and "-" ESC buttons. (see fig. below).

The description of the menus and of each individual parameter will be shown on the display.

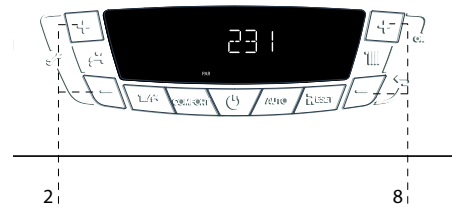

- "+" and "-" buttons to access and modify the parameters.
- "+" OK button to store the adjustments of various parameters.
- "-" ESC button to exit from the parameters.

The menus and parameters number is shown by the figures of the display.

**CAUTION!** THE MENUS RESERVED FOR QUALIFIED TECHNICIANS MAY ONLY BE ACCESSED AFTER SETTING THE ACCESS CODE.

To access the Menus, open the cover and proceed as follows (for example: 231)

- Simultaneously press the 2 "+" and "-" buttons for 5 seconds. Insert the service code, the display shows 222
- Press the "+" button to select 234.
- Press the "+" OK button. the display shows the first "quick setting" GAS
- Press the "+" button to select MENU (Complete MENU)
- Press the "+" OK button. The display shows menu 0
- Press the "+" button to select menu 2.
- Press the "+" OK button to access to the menu. The display shows the sub-menu 20.
- Press the "+" button to select the sub-menu 23.
- Press the "+" OK button to access to the sub-menu. The display shows the parameter 230.
- Press the "+" button to select the parameter 231.
- Press the "+" OK button to access to the parameter. The display shows the value "ex: 70".
- Press the 2 "+" or "-" button to select the new value "ex: 75"
- Press the "+" OK button to save the change or press "-" ESC button to exit without saving.



Press the "-" ESC button until the normal display screen is restored.

## SETTINGS - ADJUSTMENT - PROBLEM IDENTIFICATION MENUS

menu	sub-menu	Parameter	Description	value	default setting	
------	----------	-----------	-------------	-------	-----------------	--

SERVICE CODE						
Press the button "+"  to select code 234 and press Ok. Turn the encoder to select MENU and press OK button						
<b>0</b>	<b>NETWORK</b>					
<b>0</b>	<b>4</b>	<b>DISPLAY SETTING</b>				
<b>0</b>	<b>4</b>	<b>0</b>	Zone to be set by display	1 = 1 Zone 2 = 2 Zone 3 = 3 Zone	<b>1</b>	
<b>0</b>	<b>4</b>	<b>1</b>	Backlight timing	from 0 to 10 (minutes) or 24 (hour)	24	
<b>0</b>	<b>4</b>	<b>2</b>	Thermoregulation button deactivation	0 = OFF 1 = ON	0	
<b>2</b>	<b>BOILER PARAMETER SETTING</b>					
<b>2</b>	<b>0</b>	<b>GENERAL</b>				
<b>2</b>	<b>0</b>	<b>0</b>	DHW Setpoint Temperature	from 36 to 60 (°C)		Setting by DHW button 2
<b>2</b>	<b>0</b>	<b>1</b>	DHW Pre-heating	0 = OFF 1 = ON		RESERVED FOR TECHNICAL ASSISTANCE Only if the PCB is changed
<b>2</b>	<b>1</b>	<b>BOILER PARAMETERS</b>				
<b>2</b>	<b>0</b>	<b>0</b>	Boiler circulator type (NOT ACTIVE)			
<b>2</b>	<b>2</b>	<b>BOILER GENERAL SETTINGS</b>				
<b>2</b>	<b>2</b>	<b>0</b>	Soft ignition	from 0 to 90	60	See parag. Gas settings
<b>2</b>	<b>2</b>	<b>3</b>	Underfloor thermostat or zone 2 ambient thermostat selection	0 = Floor safety thermostat 1 = Zone 2 ambient thermostat	0	
<b>2</b>	<b>2</b>	<b>4</b>	Thermoregulation	0 = Absent 1 = Present	0	
<b>2</b>	<b>2</b>	<b>5</b>	Heating ignition delay	0 = Deactivated 1 = 10 seconds 2 = 90 seconds 3 = 210 seconds	0	
<b>2</b>	<b>2</b>	<b>8</b>	Boiler Version - <b>E-COMBI ONE</b> CANNOT BE MODIFIED	from 0 to 5	0	RESERVED FOR TECHNICAL ASSISTANCE Only if the PCB is changed
			Boiler Version - <b>E-SYSTEM ONE</b> CANNOT BE MODIFIED	from 0 to 5	2	
<b>2</b>	<b>2</b>	<b>9</b>	Set boiler heat power			
<b>2</b>	<b>3</b>	<b>BOILER PARAMETER - PART 1</b>				
<b>2</b>	<b>3</b>	<b>1</b>	Maximum heating power setting	from 0 to 99	60	see the "Gas setting" table, information on Starting
<b>2</b>	<b>3</b>	<b>2</b>	Domestic hot water maximum percentage CANNOT BE MODIFIED	from 0 to 99		RESERVED FOR TECHNICAL ASSISTANCE Only if the gas or PCB is changed see "gas setting" table
<b>2</b>	<b>3</b>	<b>3</b>	Minimum percentage CANNOT BE MODIFIED	from 0 to 99		
<b>2</b>	<b>3</b>	<b>4</b>	Heating maximum percentage CANNOT BE MODIFIED	from 0 to 99		
<b>2</b>	<b>3</b>	<b>5</b>	Selection of ignition delay type when heating	0 = Manual 1 = Automatic	1	
<b>2</b>	<b>3</b>	<b>6</b>	Ignition delay when heating timer setting	from 0 to 7 (minutes)	3	
<b>2</b>	<b>3</b>	<b>7</b>	Post-circulation when heating	from 0 to 15 minutes or OC (AC)	3	
<b>2</b>	<b>3</b>	<b>8</b>	<Not Available>			
<b>2</b>	<b>3</b>	<b>9</b>	<Not Available>			

## SETTINGS - ADJUSTMENT - PROBLEM IDENTIFICATION MENUS

menu	sub-menu	Parameter	Description	value	default setting		
<b>2</b>	<b>4</b>	<b>BOILER PARAMETER - PART 2</b>					
2	4	3	Post-ventilation after heating request	0 = OFF 1 = ON	0		
2	4	4	Time delay after heating temperature increase	from 0 to 60 (minutes)	16	Activated only with thermostat On/Off and heating control activated (parameter 421 - 521 - 621 = 01)	
			This parameter allows the time delay to be set before automatic increase of the flow temperature calculated in increments of 4°C (max 12°C). If this parameter retains the value 00, this function is not active.				
2	4	5	Circulation pump MAX speed	from 75 to 100			
2	4	6	Circulation pump MIN speed	from 40 to 100			
2	4	7	Device indicator for heating circuit pressure	0 = temperature sensor only 1 = pressure switch at minimum 2 = pressure sensor	1	RESERVED FOR TECHNICAL ASSISTANCE Only if the PCB is changed	
2	4	8	<Not Available>				
2	4	9	External temperatura correction	from -3 to +3 (°C)	0	Only active with external sensor connected	
<b>2</b>	<b>5</b>	<b>DOMESTIC HOT WATER PARAMETER</b>					
2	5	0	COMFORT function <b>E-COMBI ONE</b>	0 = deactivated 1 = timed 2 = always on	0	Timer = activated for 30 minutes after domestic hot water draw-off	
			The appliance allows the hot water heating comfort to be increased via the "COMFORT" function. This function keeps the secondary exchanger temperature stable when the boiler is not in use. When the function is active, the display shows COMFORT Note: this function can be activated and deactivated by pressing the COMFORT button				
							
2	5	1	Comfort Anti-cycling Time <b>E-COMBI ONE</b>	from 0 to 120 (minutes)	0		
2	5	2	Hot water flow delay <b>E-COMBI ONE</b>	from 5 to 200 (0.5 to 20 seconds)	5	Anti "water hammering"	
2	5	3	Extinction of the burner in D. H. W. <b>E-COMBI ONE</b>	0 = anti-scale (stop at > 67°C) 1 = + 4°C /setting	0		
2	5	4	Post-circulation and post-ventilation after a domestic hot water draw-off	0 = OFF 1 = ON	0		
			OFF = 3 minutes post-circulation and post-ventilation after domestic hot water draw-off if the boiler temperature measured requires it. ON = always on for 3 minutes post-circulation and post-ventilation after domestic hot water draw-off.				
							
2	5	5	Domestic hot water timer	from 0 to 30 (minutes)	0		
2	5	7	<Not Available>				
2	5	8	<Not Available>				
<b>2</b>	<b>6</b>	<b>BOILER MANUAL SETTINGS</b>					
			Only to test components				
2	6	0	Manual mode activation	0 = OFF 1 = ON	0		
2	6	1	Boiler pump control	0 = OFF 1 = ON	0	Set parameter 260=1	
2	6	2	Fan control	0 = OFF 1 = ON	0	Set parameter 260=1	
2	6	3	3 way valve control	0 = Sanitary 1 = Heating	0	Set parameter 260=1	
2	6	4	<Not Available>				
<b>2</b>	<b>7</b>	<b>TEST &amp; UTILITIES</b>					
2	7	0	Test mode	TEST+     = Max Heating power TEST+     = Max DHW power TEST+     = Minimum power.		activation can also be obtained by pressing the <b>Reset</b> button for 10 seconds. The function is deactivated after 30 minutes or by pressing <b>Reset</b>	

## SETTINGS - ADJUSTMENT - PROBLEM IDENTIFICATION MENUS

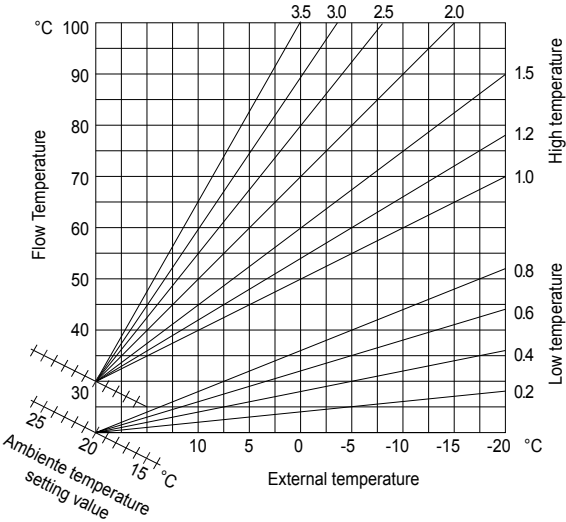
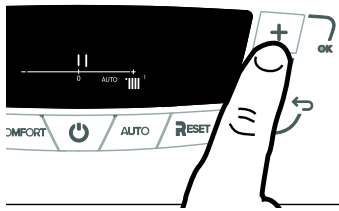
menu	sub-menu	Parameter	Description	value	default setting		
2	7	1	Bleed cycle	press <b>OK</b> button for 5 seconds		see First Ignition parag.	
2	8	<b>RESET MENU' 2</b>					
2	8	0	Automatically resetting to the default setting in menu 2	Reset OK = yes ESC = no		To reset all default parameter settings, press the OK button	
4	<b>ZONE 1 PARAMETER</b>						
4	0	<b>ZONE 1 TEMPERATURE SETTING</b>					
4	0	2	Heating fixed temperature setting "Heating fixed temp"	from 35 to 82 °C (high temperature - para. 420 =1)  from 20 to 45 °C (high temperature - para. 420 =0)	70  20	Activated only with temperature control and fixed temperature (see 421)	
4	2	<b>ZONE 1 SETTING</b>					
4	2	0	Heating appliance temperature value setting	0 = from 20 to 45°C (low temperature) 1 = from 35 to 85°C (high temperature)		select in the appliance type base	
4	2	1	Basic heating control type selection type depending on the peripheral devices connected	0 = fixed flow temperature 1 = device On/Off 2 = room sensor 3 = external sensor only 4 = room sensor + external sensor	1	To activate heating control, press the AUTO button. The display lights up the AUTO symbol  	
4	2	2	Slope	from 0_2 to 0_8  from 1_0 to 3_5	1_5	(low temperature)  (high temperature)	
						<p>If the external sensor is used, the boiler calculates the most suitable heating flow temperature taking the external temperature and the type of appliance into account. The type of curve must be chosen according to the type of appliance radiator and the heat losses present in the building.</p>	
4	2	3	Parallel shift	from - 7 to + 7 (low temperature) from - 14 to + 14 (high temperature)	0	<p>To adapt the thermal curve to the appliance requirements, it is possible to perform a parallel shift of the curve in order to alter the calculated flow temperature and therefore the ambient temperature.</p> <p>By accessing this parameter or pressing the buttons 8 the curve can be shifted in a parallel manner as indicated in the figure shown below.</p> <p>The value is indicated on the display:</p> <ul style="list-style-type: none"> <li>- from -7 to +7 (low temperature)</li> <li>- from -14 to +14 (high temperature)</li> </ul> <p>Each step represents a flow temperature increase/decrease of 1°C in relation to the set-point value.</p>	
							

## SETTINGS - ADJUSTMENT - PROBLEM IDENTIFICATION MENUS

menu	sub-menu	Parameter	Description	value	default setting	
4	2	4	Compensation	from 0 to 20	20	
			if setting = 0, the temperature taken from the ambient sensor does not affect the calculation of the setting. If setting = 20, the temperature taken has maximum influence on the setting.			
4	2	5	Zone 1 heating MAXIMUM temperature setting	from 35 to 85 °C	82	if parameter 420 = 1
				from 20 to 45 °C	45	if parameter 420 = 0
4	2	6	Zone 1 heating MINIMUM temperature setting	from 35 to 85 °C	35	if parameter 420 = 1
				from 20 to 45 °C	25	if parameter 420 = 0
4	3	<b>DIAGNOSTICS</b>				
4	3	4	Zone 1 heat request	0 = OFF 1 = ON		
5	<b>ZONE 2 PARAMETER</b>					
5	0	<b>ZONE 2 TEMPERATURE SETTING</b>				
5	0	2	Heating fixed temperature setting "Heating fixed temp"	from 35 to 82 °C (high temperature - para. 420 =1)	70	Activated only with temperature control and fixed temperature (see 521)
				from 20 to 45 °C (high temperature - para. 420 =0)	20	
5	2	<b>ZONE 2 SETTING</b>				
5	2	0	Heating appliance temperature value setting	0 = from 20 to 45°C (low temperature) 1 = from 35 to 85°C (high temperature)	1	select in the appliance type base
5	2	1	Basic heating control type selection type depending on the peripheral devices connected	0 = fixed flow temperature 1 = device On/Off 2 = NOT PRESENT 3 = external sensor only 4 = NOT PRESENT	1	To activate heating control, press the AUTO button. The display lights up the AUTO symbol
5	2	2	Slope	from 0_2 to 0_8		(low temperature)
				from 1_0 to 3_5	1_5	(high temperature)
			- see graph on the previous page If the external sensor is used, the boiler calculates the most suitable heating flow temperature taking the external temperature and the type of appliance into account. The type of curve must be chosen according to the type of appliance radiator and the heat losses present in the building.			
5	2	3	Parallel curve shift Zone 2 Offset	from - 7 to + 7 (low temperature)	0	
				from - 14 to + 14 (high temperature)		
			To adapt the thermal curve to the appliance requirements, it is possible to perform a parallel shift of the curve in order to alter the calculated flow temperature and therefore the ambient temperature. By accessing this parameter or pressing the buttons 12 the curve can be shifted in a parallel manner as indicated in the figure shown below. The value is indicated on the display: - from -7 to +7 (low temperature) - from -14 to +14 (high temperature) Each step represents a flow temperature increase/decrease of 1°C in relation to the set-point value.			
5	2	4	Compensation	from 0 to 20	20	if setting = 0, the temperature taken from the ambient sensor does not affect the calculation of the setting. If setting = 20, the temperature taken has maximum influence on the setting.
5	2	5	Zone 2 heating MAXIMUM temperature setting	from 35 to 85 °C	82	if parameter 520 = 1
				from 20 to 45 °C	45	if parameter 520 = 0
5	2	6	Zone 2 heating MINIMUM temperature setting	from 35 to 85 °C	35	if parameter 520 = 1
				from 20 to 45 °C	25	if parameter 520 = 0

## SETTINGS - ADJUSTMENT - PROBLEM IDENTIFICATION MENUS

menu	sub-menu	Parameter	Description	value	default setting	
<b>5</b>	<b>3</b>	<b>DIAGNOSTICS</b>				
<b>5</b>	<b>3</b>	<b>4</b>	Zone 2 heat request	0 = OFF 1 = ON		
<b>6</b>	<b>ZONE 3 PARAMETER</b>					
<b>6</b>	<b>0</b>	<b>ZONE 3 TEMPERATURE SETTING</b>				
<b>6</b>	<b>0</b>	<b>2</b>	Heating fixed temperature setting "Heating fixed temp"	from 35 to 82 °C (high temperature - para. 420 =1)  from 20 to 45 °C (high temperature - para. 420 =0)	70  20	Activated only with temperature control and fixed temperature (see 621)
<b>6</b>	<b>2</b>	<b>ZONE 3 SETTING</b>				
<b>6</b>	<b>2</b>	<b>0</b>	Heating appliance temperature value setting	0 = from 20 to 45°C (low temperature) 1 = from 35 to 85°C (high temperature)	1	select in the appliance type base
<b>6</b>	<b>2</b>	<b>1</b>	Basic heating control type selection type depending on the peripheral devices connected	0 = fixed flow temperature 1 = device On/Off 2 = NOT PRESENT 3 = external sensor only 4 = NOT PRESENT	1	To activate heating control, press the AUTO button. The display lights up the AUTO symbol
<b>6</b>	<b>2</b>	<b>2</b>	Slope	from 0_2 to 0_8  from 1_0 to 3_5		(low temperature)  1_5 (high temperature)
			- see graph on page 42 If the external sensor is used, the boiler calculates the most suitable heating flow temperature taking the external temperature and the type of appliance into account. The type of curve must be chosen according to the type of appliance radiator and the heat losses present in the building.			
<b>6</b>	<b>2</b>	<b>3</b>	Parallel curve shift Zone 2 Offset	from - 7 to + 7 (low temperature) from - 14 to + 14 (high temperature)	0	
			To adapt the thermal curve to the appliance requirements, it is possible to perform a parallel shift of the curve in order to alter the calculated flow temperature and therefore the ambient temperature. By accessing this parameter or pressing the buttons 12 the curve can be shifted in a parallel manner as indicated in the figure shown below. The value is indicated on the display: - from -7 to +7 (low temperature) - from -14 to +14 (high temperature) Each step represents a flow temperature increase/decrease of 1°C in relation to the set-point value.			
<b>6</b>	<b>2</b>	<b>4</b>	Compensation	from 0 to 20	20	if setting = 0, the temperature taken from the ambient sensor does not affect the calculation of the setting. If setting = 20, the temperature taken has maximum influence on the setting.
<b>6</b>	<b>2</b>	<b>5</b>	Zone 3 heating MAXIMUM temperature setting	from 35 to 85 °C from 20 to 45 °C	82 45	if parameter 620 = 1 if parameter 620 = 0
<b>6</b>	<b>2</b>	<b>6</b>	Zone 3 heating MINIMUM temperature setting	from 35 to 85 °C from 20 to 45 °C	35 25	if parameter 620 = 1 if parameter 620 = 0
<b>6</b>	<b>3</b>	<b>DIAGNOSTICS</b>				
<b>6</b>	<b>3</b>	<b>4</b>	Zone 3 heat request	0 = OFF 1 = ON		
<b>8</b>	<b>SERVICE PARAMETERS</b>					
<b>8</b>	<b>0</b>	<b>BOILER STATISTICS-1</b>				
<b>8</b>	<b>0</b>	<b>0</b>	Number of diverter valve cycles (n x10)			
<b>8</b>	<b>0</b>	<b>1</b>	Time of circulator on (h x 10)			
<b>8</b>	<b>0</b>	<b>2</b>	Number of boiler circulator cycles (n x10)			

## SETTINGS - ADJUSTMENT - PROBLEM IDENTIFICATION MENUS

menu	sub-menu	Parameter	Description	value	default setting
8	0	3	Boiler Life Time (h x 10)		
8	0	4	Time of fan ON (h x 10)		
8	0	5	Number of fan cycles (n x10)		
8	0	6	Number of flame detection in CH (n x10)		
8	0	7	Number of flame detection in DHW (n x10)		
8	1	<b>BOILER STATISTICS-2</b>			
8	1	0	Number of hours burner operating in heater mode (xxh/10)		
8	1	1	Number of hours burner operating in hot water mode (xxh/10)		
8	1	2	Number of flame separations (nr/10)		
8	1	3	Number of ignition cycles (nr/10)		
8	1	4	Average length of heating request (minutes)		
8	2	<b>BOILER</b>			
8	2	1	Fan Status	0 = OFF 1 = ON	
8	2	2	Fan speed (x100) rpm		
8	2	4	Diverter valve position	0 = D.H.W. 1 = Central Heating	
8	2	5	D.H.W. Flow Rate (l/min)		
8	2	7	Modulating Pump (%)		
8	2	8	Gas Power (kW)		
8	3	<b>BOILER TEMPERATURE</b>			
8	3	1	Heating flow temperature (in °C)		
8	3	2	Heating backflow temperature (in °C)		
8	4	<b>SOLAR &amp; STORAGE</b>			
8	4	2	Solar appliance water input temperature		activated only with the solar kit connected
8	5	<b>SERVICE</b>			
8	5	0	Months to next maintenance	from 0 to 60 (month)	24
			If setted the boiler will display that is time to call the installer for maintenance		
8	5	1	Enable Maintenance advice	0 = OFF 1 = ON	0
8	5	2	Maintenance Warning Reset	Reset? OK= Yes Esc = No	
			to erase the advice for maintenance		
8	5	3	2nd Heat Exchanger Clogging State	0 = DHW Exchanger OK 1 = Partially Clogged 2 = Very Clogged Please Replace	
8	5	4	PCB hardware version		
8	5	5	PCB software version		
8	6	<b>ERROR LIST</b>			
8	6	0	10 last errors	from ERROR 0 to ERROR 9	
			This parameter allows the last 10 boiler errors flagged to be displayed, indicating the day, month and year. When the parameter is accessed, the errors are displayed listed from ERROR 0 to ERROR 9. For each error, the following sequence is displayed: E00 - error number 108 - error code		
8	6	1	Error list reset	Reset OK = yes ESC = no	

### Important

Maintenance is an essential part of the safe and efficient operation of the boiler and ensures its durability. It should be performed according to the instructions given in current legislation. Perform combustion analysis regularly in order to check the operating efficiency of the boiler and to make sure any polluting substances released are within the boundaries set by current legislation.

Before beginning maintenance work:

- Disconnect the appliance from the electricity supply by turning the external bipolar switch to the "OFF" position;
- Close the gas valve and the central heating and domestic hot water system valves.

After the work has been completed the initial settings will be restored.

**After servicing, complete the relevant Service Interval Record section of the Benchmark Checklist located on the inside back pages of this document**



### General comments

It is recommended that the following inspections be carried out on the boiler at least once a year:

1. Check the seals in the water part and, if necessary, replace the gaskets and restore the seal to perfect working order.
2. Check the seals in the gas part and, if necessary, replace the gaskets and restore the seal to perfect working order.
3. Visually check the overall condition of the boiler.
4. Visually check and, if necessary, disassemble and clean the burner.
5. Following the inspection detailed in point "3", disassemble and clean the combustion chamber, if necessary.
6. Following the inspection detailed in point "4", disassemble and clean the burner, if necessary.
7. Cleaning the primary heat exchanger
8. Make sure the following heating safety devices are operating correctly:
  - temperature limit safety device.
9. Make sure that the following gas part safety devices are operating correctly:
  - absence of gas or flame safety device (ionisation).
10. Check the efficiency of the domestic hot water production process (test the flow rate and temperature).
11. Perform a general inspection of the boiler operation.
12. Remove oxide from the detection electrode using an emery cloth.
13. These checks are not exhaustive. Further mechanical, electrical and combustion maintenance checks may be required.

### Operational test

After having carried out the maintenance operations, fill the heating circuit at a pressure of approximately 1.5 bar and release the air from the system.

Fill the domestic hot water system at the same time.

- Begin operating the boiler.
- If necessary, release the air from the heating system again.
- Check the settings and make sure all the command, adjustment and monitoring parts are working correctly.
- Check the flue system is sealed and operating correctly.

### Draining procedures

The heating system must be drained using the following procedure:

- Switch off the boiler, make sure the external bipolar switch is in the OFF position and shut off the gas valve;
- Loosen the automatic air relief valve;
- Open the system drain off cock and collect the escaping water in a container;
- Empty the water from the lowest points of the system (where applicable).

If the system is to be left inactive in areas where the room temperature may fall below 0°C during winter, we recommend that anti-freeze liquid is added to the water in the heating system in order to avoid the need for repeated draining; when this liquid is used make sure it is compatible with the stainless steel used for the bodywork of the boiler.

We recommend the use of anti-freeze products which contain PROPYLENE GLYCOLS as these inhibit corrosion and that they are used in conjunction with the anti-scaling and anti-corrosion function, in the quantities suggested by the manufacturer, at the minimum temperature.

Regularly check the pH level of the water/anti-freeze mix in the boiler circuit and replace it when the value measured is lower than the limit prescribed by the manufacturer.

#### **DO NOT MIX DIFFERENT TYPES OF ANTI-FREEZE.**

The manufacturer will not be held liable for any damage caused by the appliance or the system due to the use of inappropriate anti-freeze substances or additives.

### Draining the domestic hot water system and indirect cylinder

Every time there is a danger of freezing, the domestic hot water system must be drained as follows:

- Shut off the water mains inlet valve;
- Open all the hot and cold water taps;
- Empty the water from the lowest points of the system (where applicable).

### WARNING

Before handling, empty all components which may contain hot water, performing bleeding where necessary.

Descal the components in accordance with the instructions provided on the safety data leaflet supplied with the product used, make sure the room is well ventilated, wear protective clothing, avoid mixing different products, and protect the appliance and surrounding objects.

Seal all openings used to take a gas pressure reading or to make any gas adjustments.

If a smell of burning is detected or smoke is seen leaking from the appliance, or there is a smell of gas, disconnect it from the electricity supply, shut off the gas valve, open the windows and call for technical assistance.

### Cleaning the primary exchanger

Cleaning the combustion side

The inside of the primary exchanger is accessed by removing the burner. Wash with water and detergent using a non-metallic rifle-type brush, rinse with water.

### Cleaning the trap

The trap is accessed by emptying the condensate bowl located in the bottom section. Wash with water and detergent.

Replace the condensate collection bowl in its housing.

NB: In the event of prolonged use of the appliance, the trap must be filled before being used again.

A lack of water in the trap is dangerous and may cause products to be released into the atmosphere.

## 1. GENERAL ACCESS

### 1.0 Disconnect the boiler

Before beginning maintenance work:

- a. Disconnect the appliance from the electricity supply.  
Press the ON/OFF button and wait 1 minute (the 3-way valve turn on Stand-by position)  
**ATTENTION!! With the 3-way valve on heating position is not possible to remove the motor.**  
Turn the external bipolar switch to the "OFF" position.
- b. Close the gas valve and the central heating and domestic hot water system valves.



Remove the front panel

2

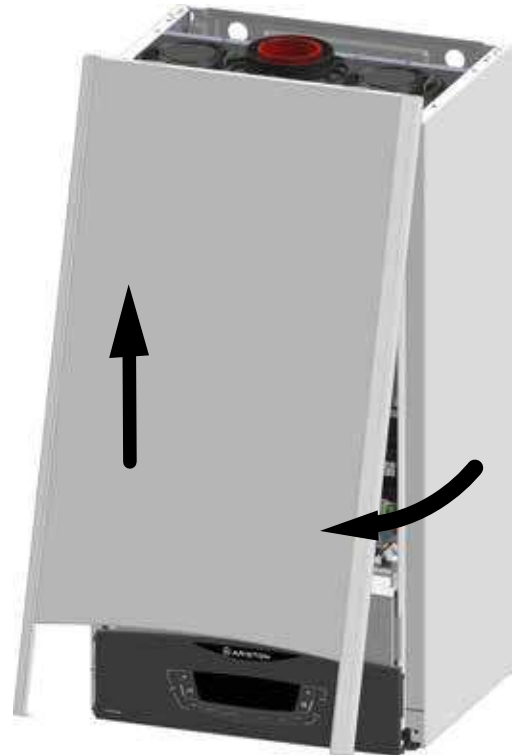

Lower the electrical front panel

3

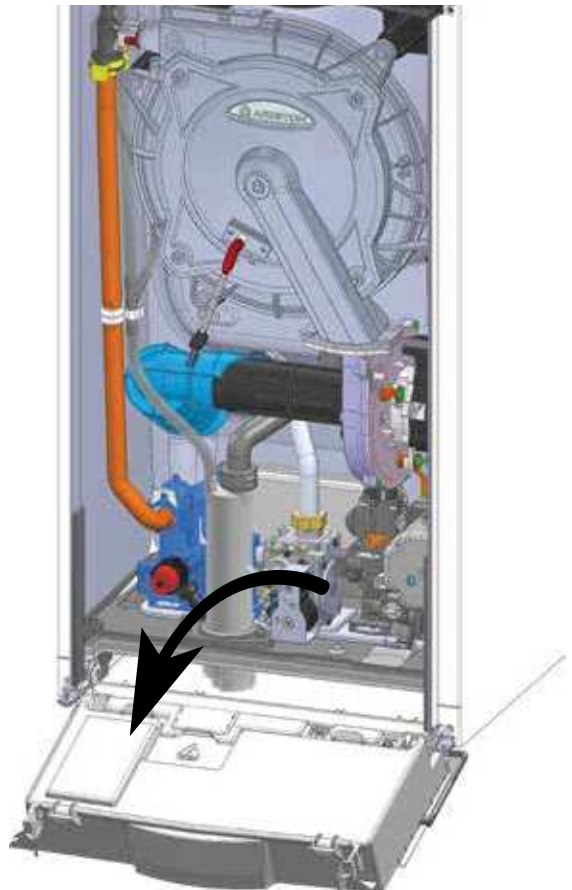

### 1.1 General Access

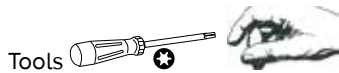

TIME  3 min

Remove the two screws

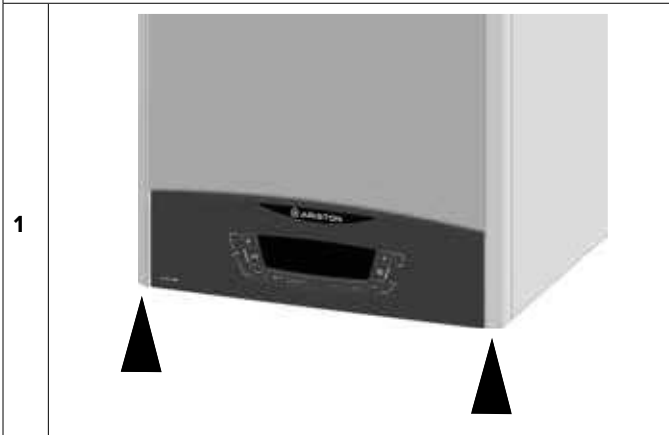

**2. ELECTRICAL UNIT**

**2.1 Control box access**

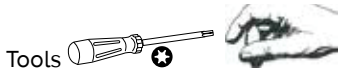

TIME  4 min

Remove the front panel as above and pivot the electrical box

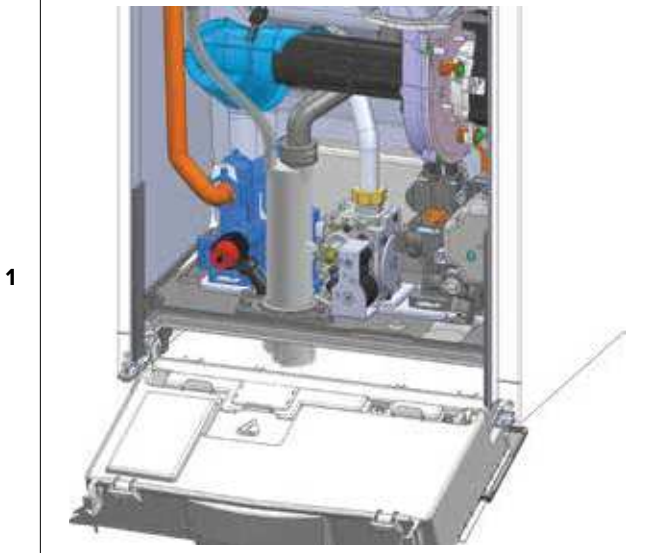

Unhook the two clips and remove the cover

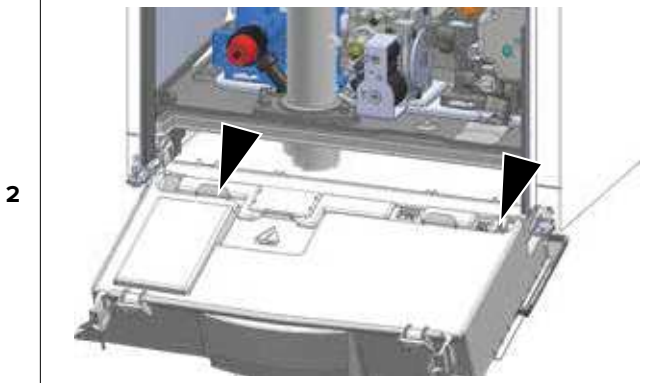

Unscrew the two screws and remove the cover of the instrument panel to have access to the main P.C.B.

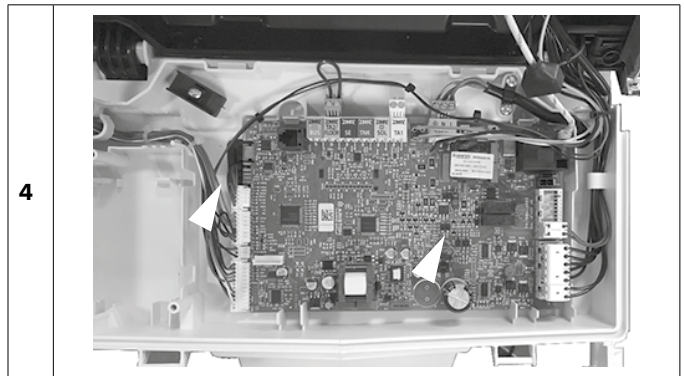
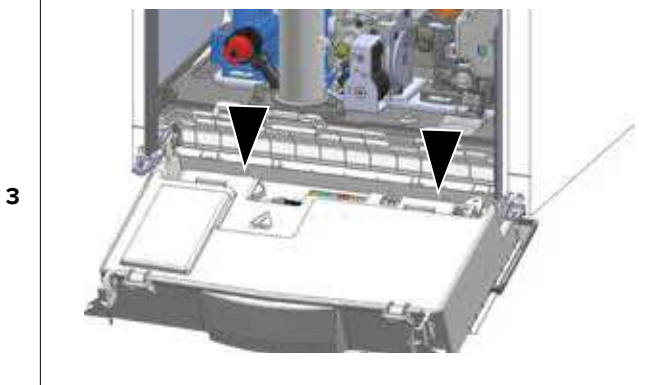

**2.2 Fuse**

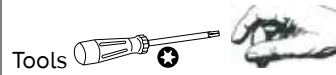

TIME  5 min

Open the control box as above

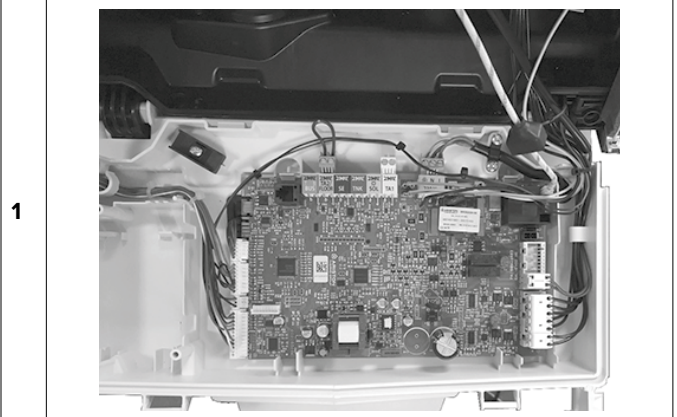

Remove the fuse

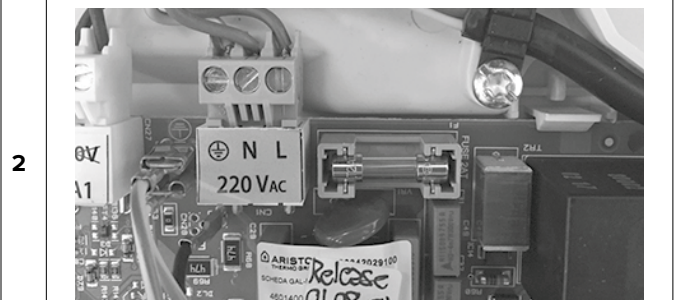

**2.3 Main P.C.B.**

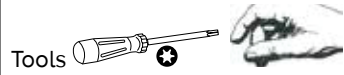

TIME  5 min

After opening the control box, disconnect the electrical plug connections

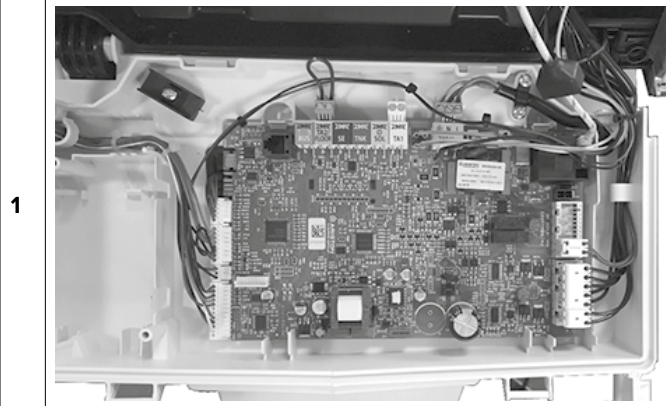

Unhook and remove the P.C.B.

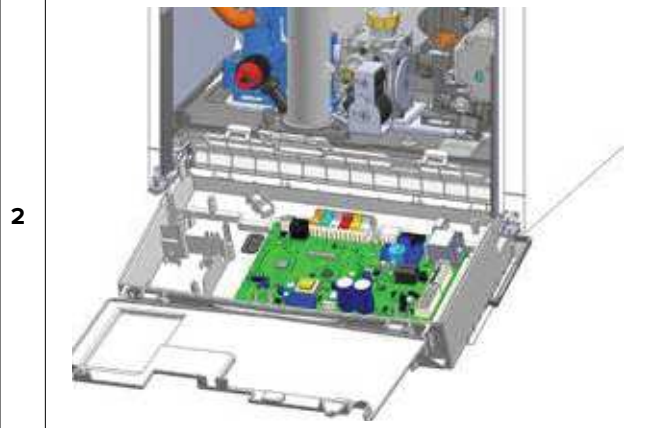

**2.4 Display P.C.B.**

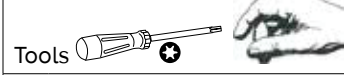

TIME  5 min

Unscrews the two screws and pull the assembly towards you

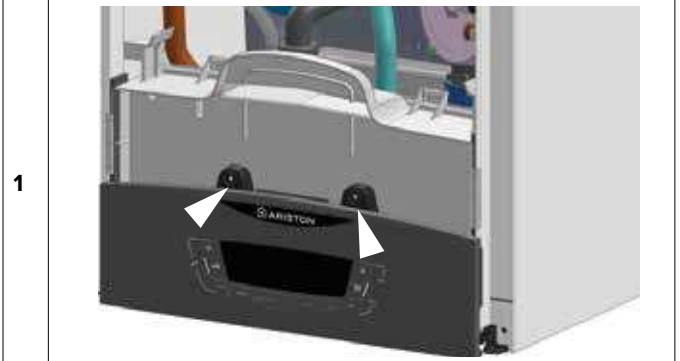

Disconnect the electrical plug connections and unhook and remove the P.C.B.

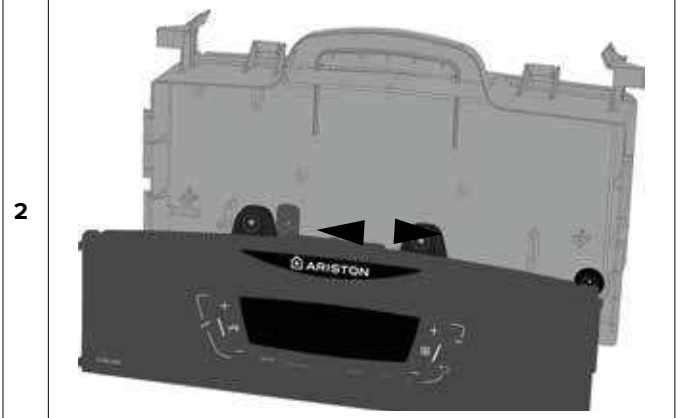

### 3. HYDRAULIC UNIT

#### 3.1 RIGHT HAND HYDRAULIC BLOCK ASSEMBLY

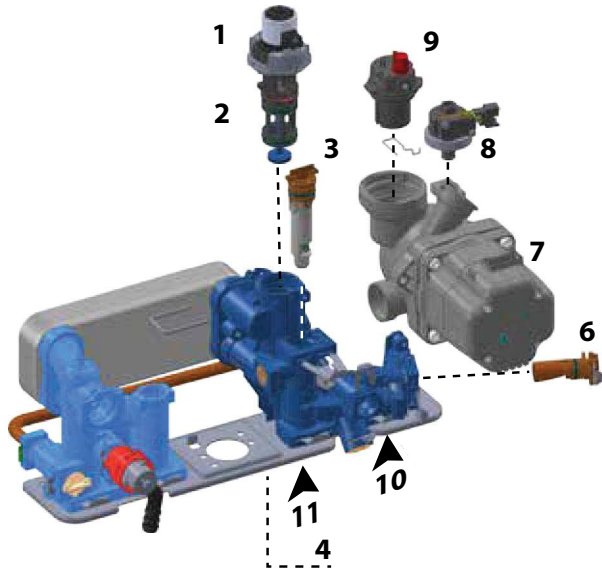

Legend:

- 1 - Diverter valve motor
- 2 - Diverter valve
- 3 - D.H.W. flow switch assembly
- 4 - C.H. drain valve
- 6 - Central heating filter
- 7 - Pump
- 8 - Primary water pressure switch
- 9 - Auto air vent
- 10 - Central Heating return
- 11 - Cold water inlet (D.H.W.)

#### 3.2. 3 Way valve unit



TIME 5 min

Drain the boiler (see 3.3).  
Unplug the diverter valve cable

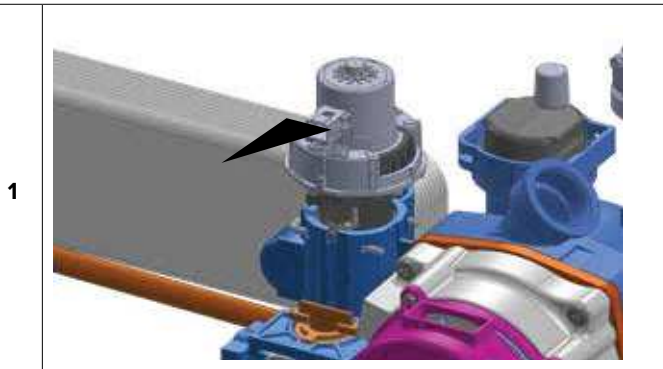

Rotate clockwise to unhook the locking ring.

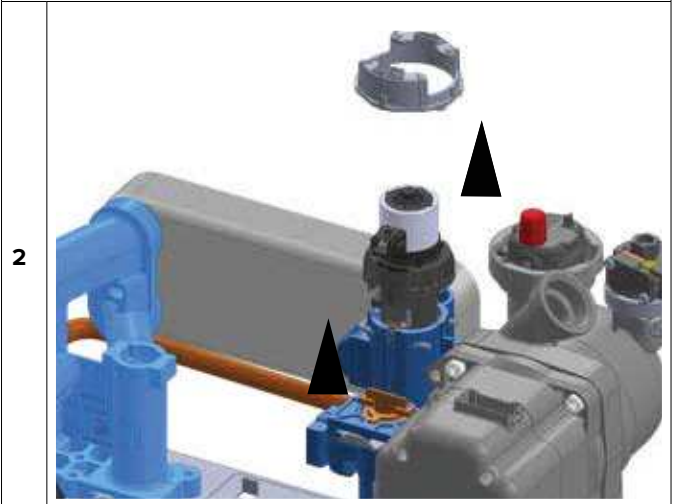

Remove the 3 way valve motor.

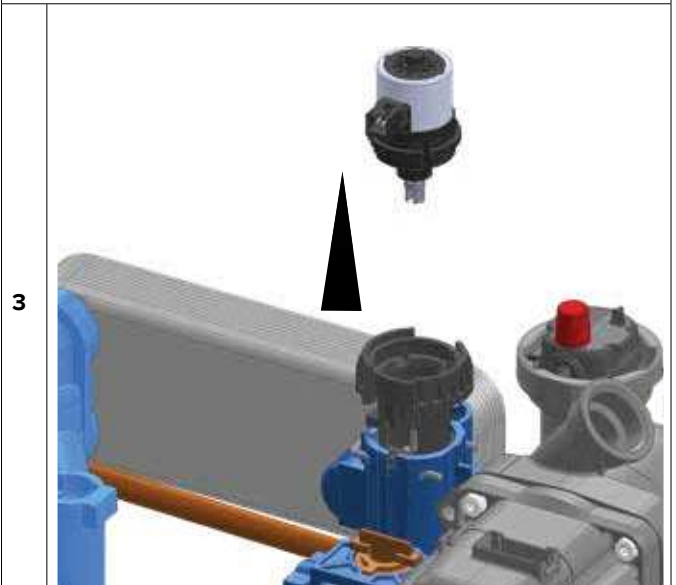

Remove the clip and lift the diverter valve from the assembly.

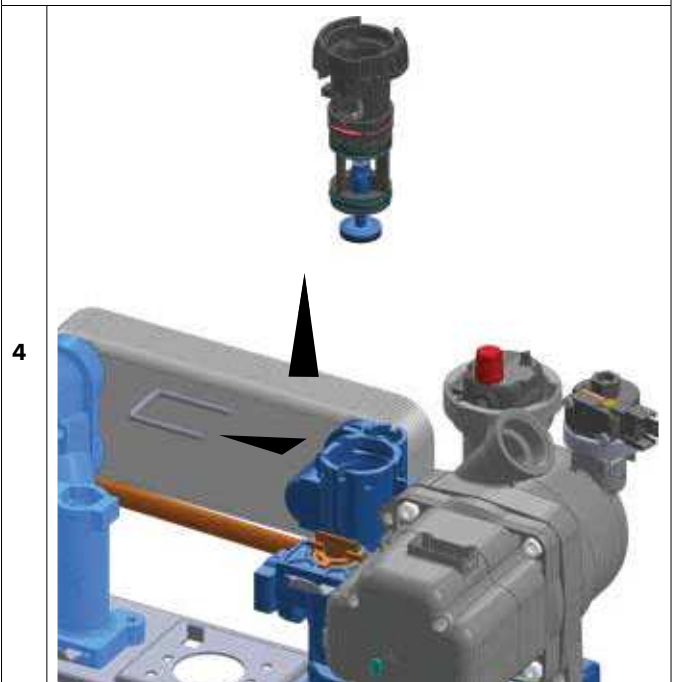

**WHEN REASSEMBLING, ENSURE THE DIVERTER VALVE IS ALIGNED CORRECTLY.**

### 3.3 Draining



TIME  5 min

Turn the drain valve anti-clockwise to open and drain the water from the boiler

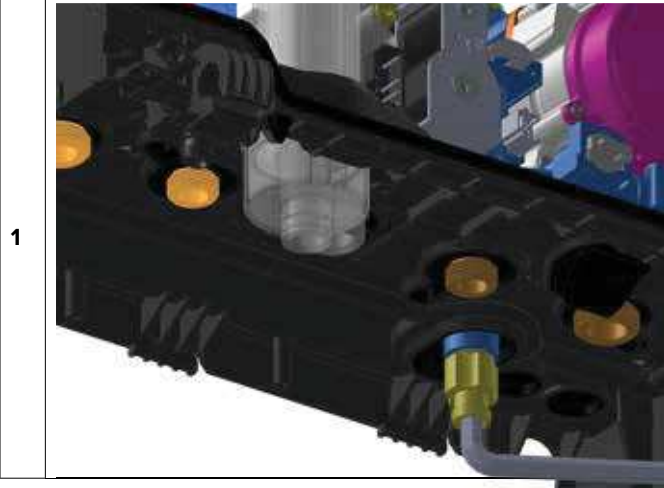

### 3.4 Automatic air vent



TIME  5 min

Drain the boiler (see 3.3).  
Unscrew anticlockwise the AAV from the assembly.



### 3.5 Primary water pressure sensor



TIME  5 min

Drain the boiler (see 3.3).  
Slide the fixing clip, (it is held captive) unplug the electrical connector and lift the sensor from the assembly.



**3.6 Pump**

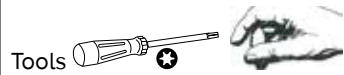

TIME  10 min

Drain the boiler (see 3.3). Remove the clip and the two screws

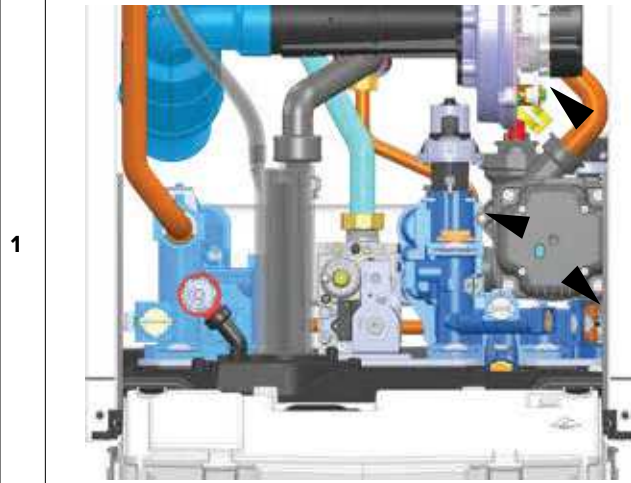

Disconnect the pipe and then move the pump to the right to disengage

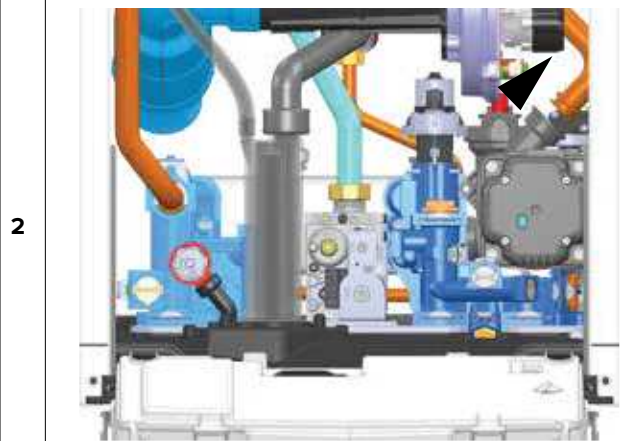

Remove the pump



Remove the sensor (see 3.5)



Remove the AAV (see 3.4)



**3.7 C.H. Filter**



TIME  5 min

Drain the boiler (see 3.3).  
Remove the clip and remove the pressure gauge

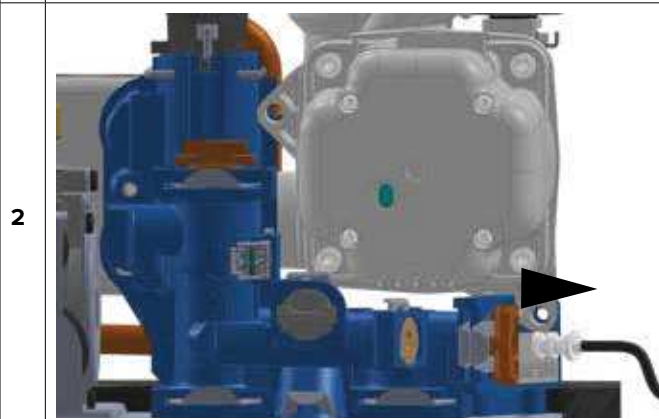
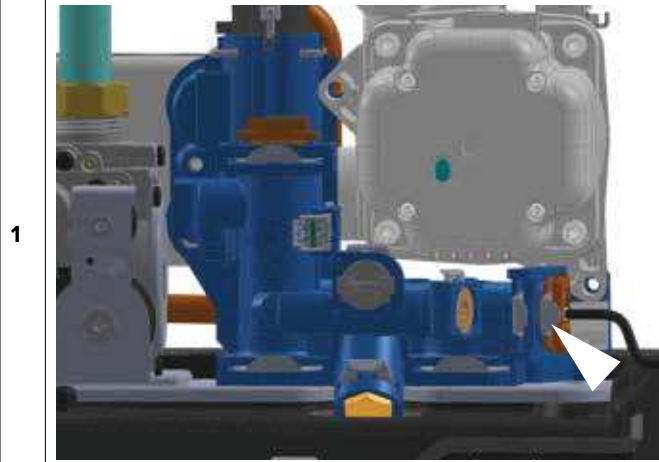

Remove the clip and remove the filter

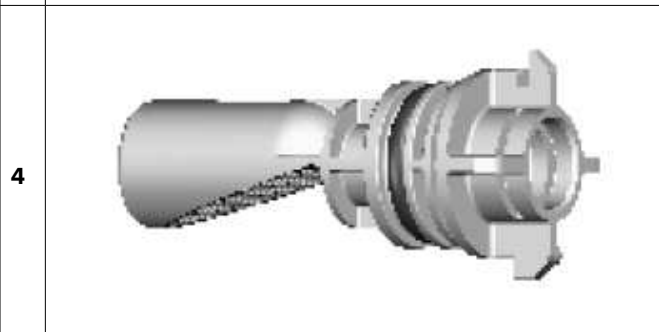

**3.8 D.H.W. Flow switch assembly**



TIME  10 min

Drain the boiler (see 3.3). Remove the clip and pull the flow switch assembly upward.

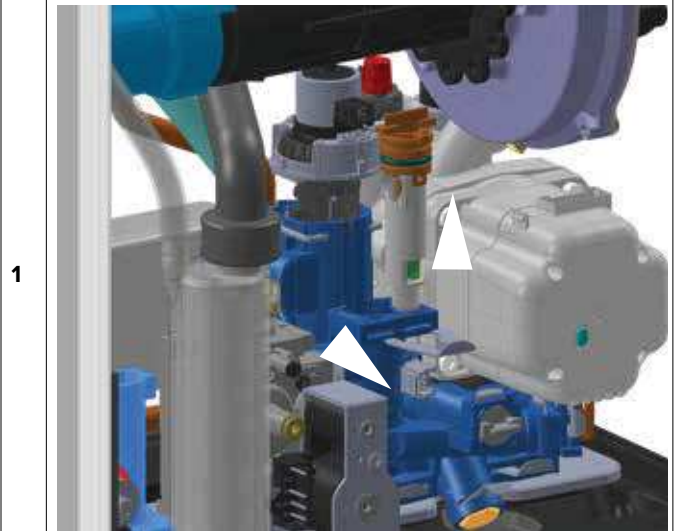

3.9 LEFT HAND HYDRAULIC BLOCK ASSEMBLY

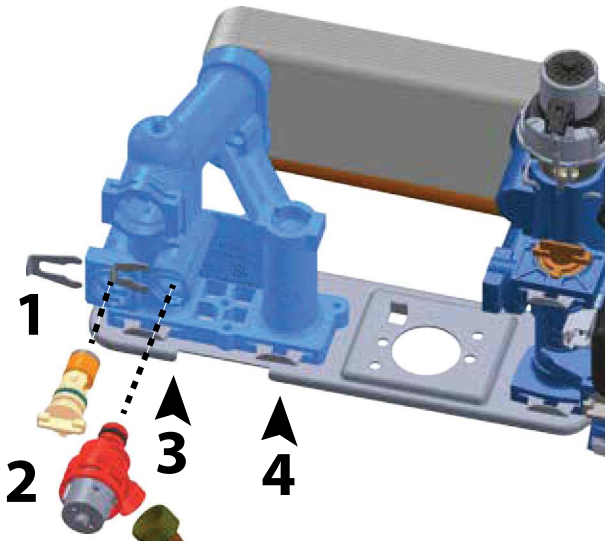

Legend:

- 1 - By-pass assembly
- 2 - Safety valve
- 3 - Central heating flow
- 4 - Domestic hot water outlet

3.10 Secondary heat exchanger

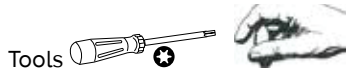

TIME  10 min

Drain primary and domestic hot water circuits.  
Remove the silencer.

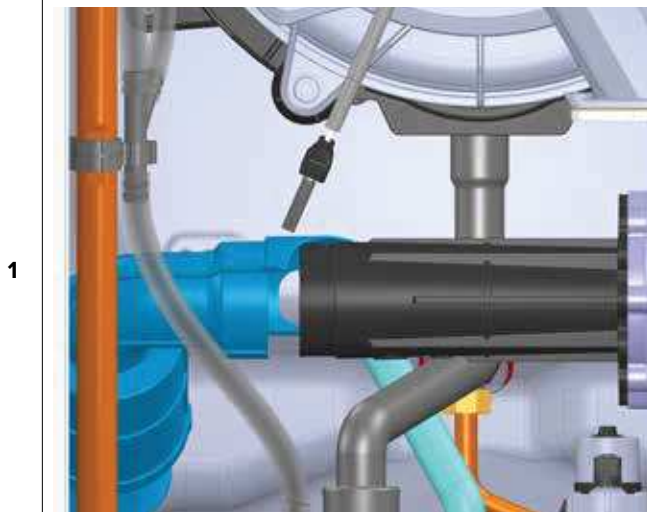

Remove the two screws and remove the heat exchanger

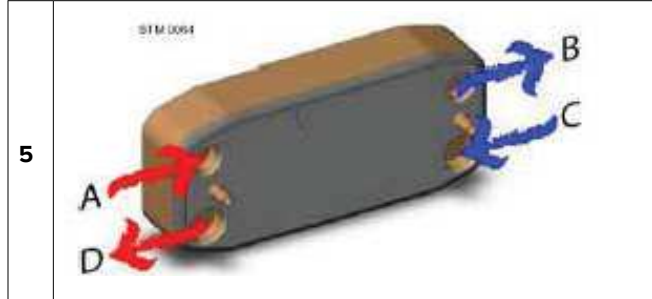
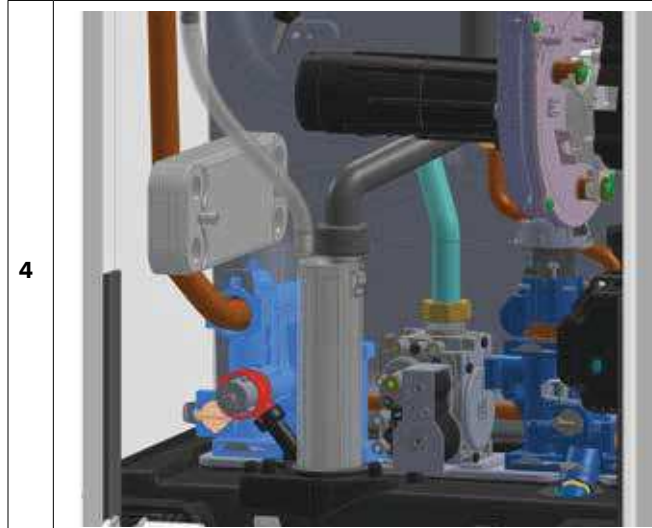
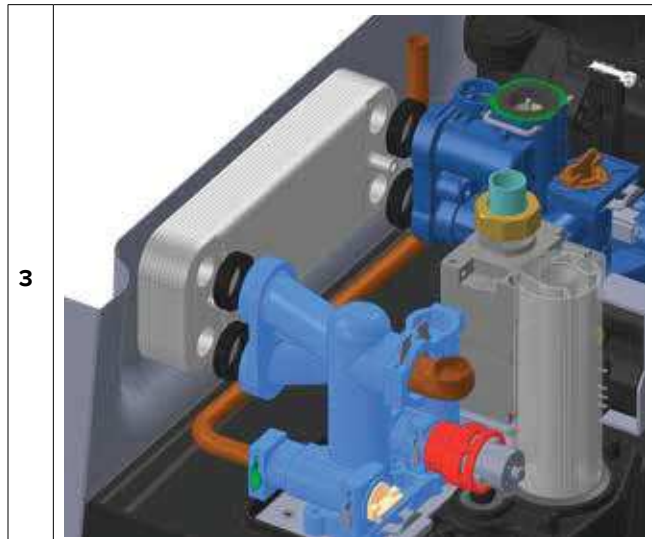
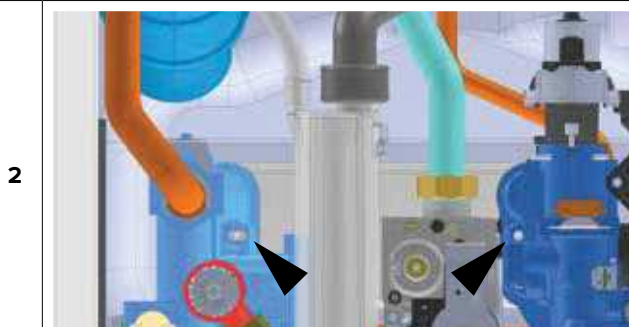

**3.11 Condensate trap**

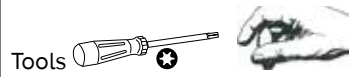

TIME  5 min

Disconnect the condensate discharge pipe from the bottom of the boiler. Unscrew the two screws.

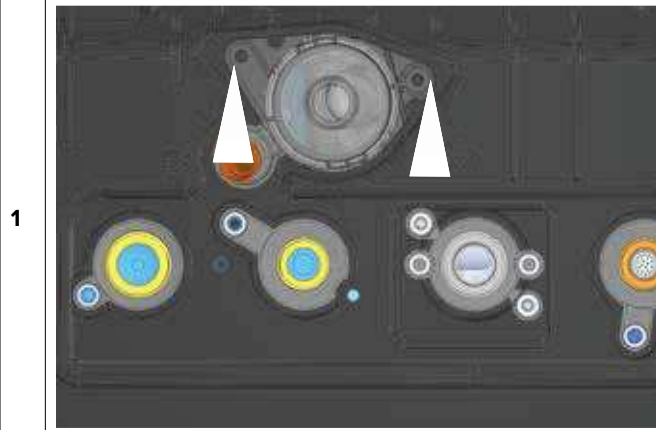

Disconnect the condensate pipe from the condensate trap

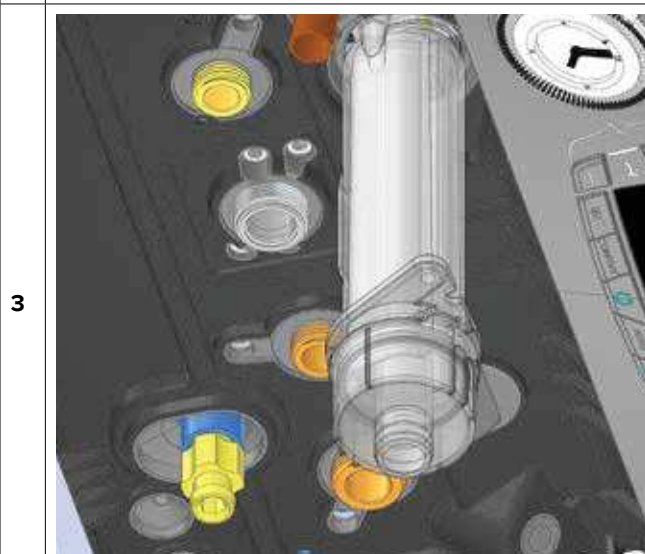
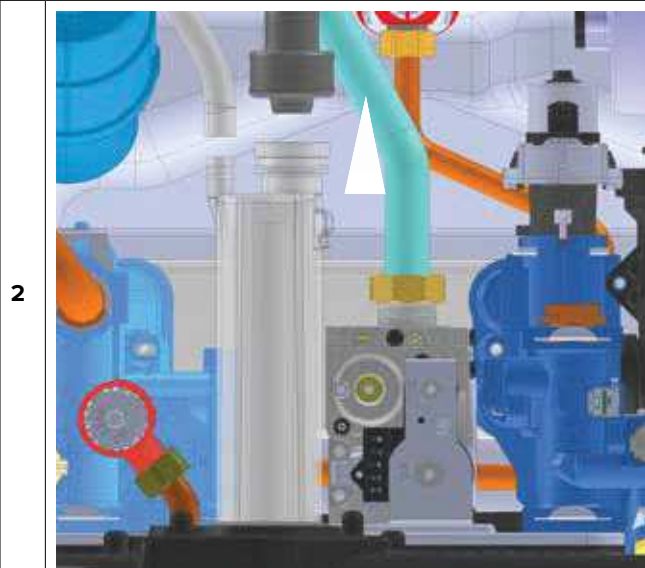

**3.12 Safety valve**



TIME  5 min

Drain the boiler (see 3.3). Disconnect the discharge pipe. Remove the fist clip on the left and pull the safety valve towards you

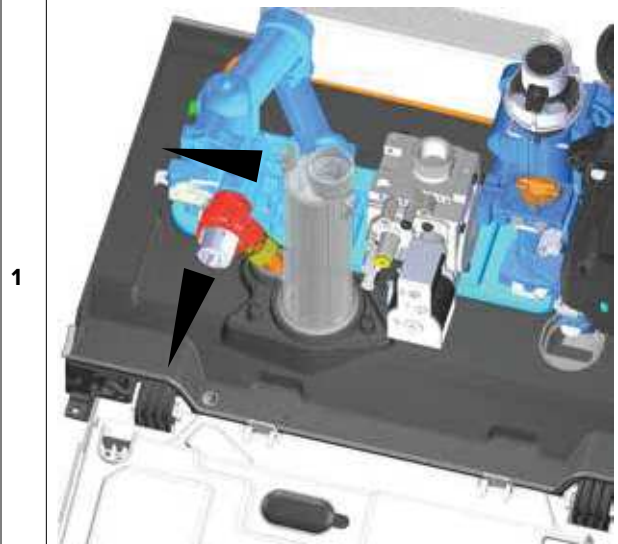

3.14 By-pass assembly

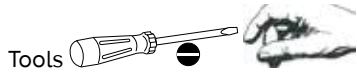

TIME  5 min

Drain the boiler (see 3.3). Remove the clip and pull the assembly towards you

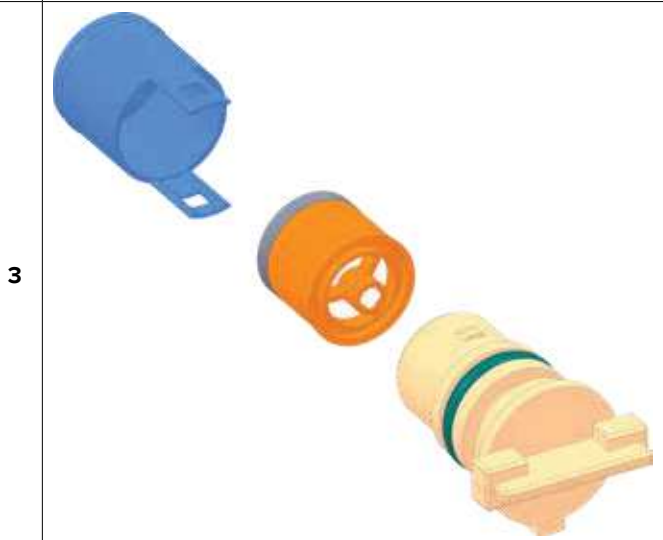
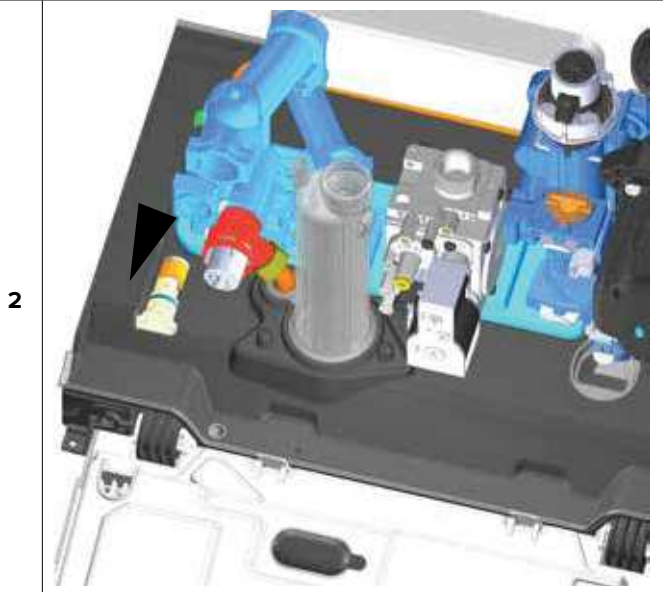
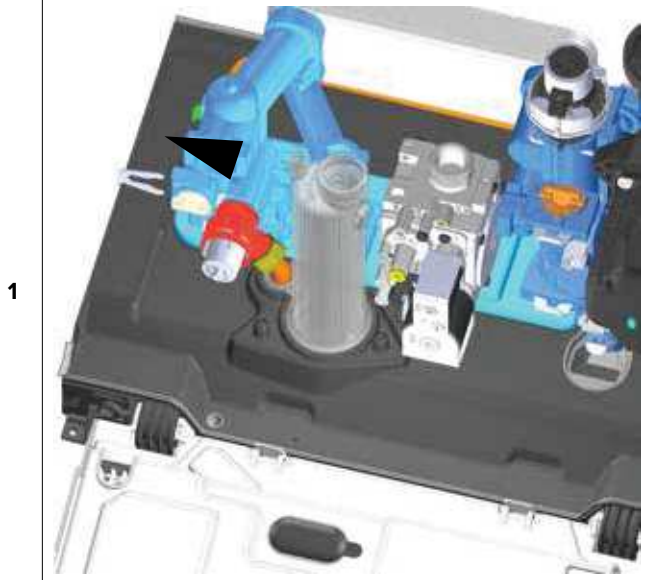

3.15 Temperature sensors



TIME  5 min

NTC1 : Black  
NTC2 : Red

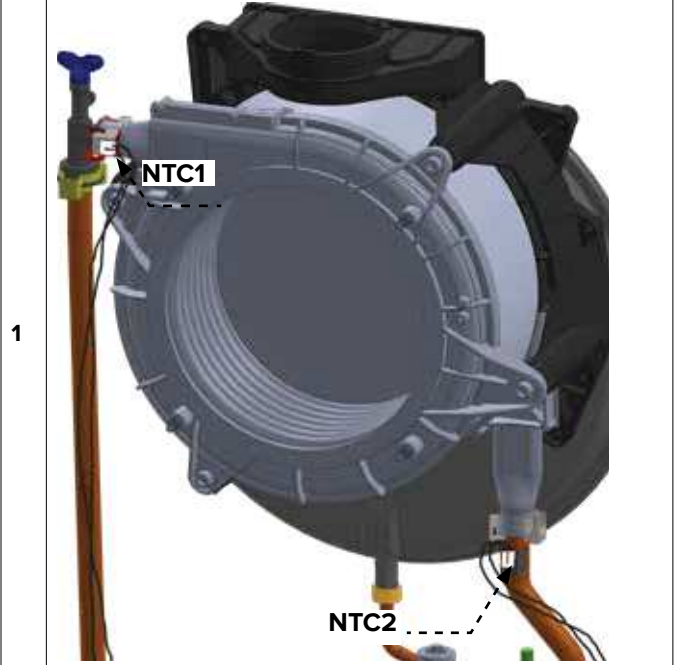

Unplug the electrical connectors



Remove the clip and the temperature sensor

**IMPORTANT !** Do not use conducting paste for the contact sensors because it will alter the resistance value.

TEMPERATURE	RESISTANCE (kOhm)
0	27
10	17
20	12
25	10
30	8
40	5
50	4

**3.16 Manual Air vent**



Tools 

TIME  5 min

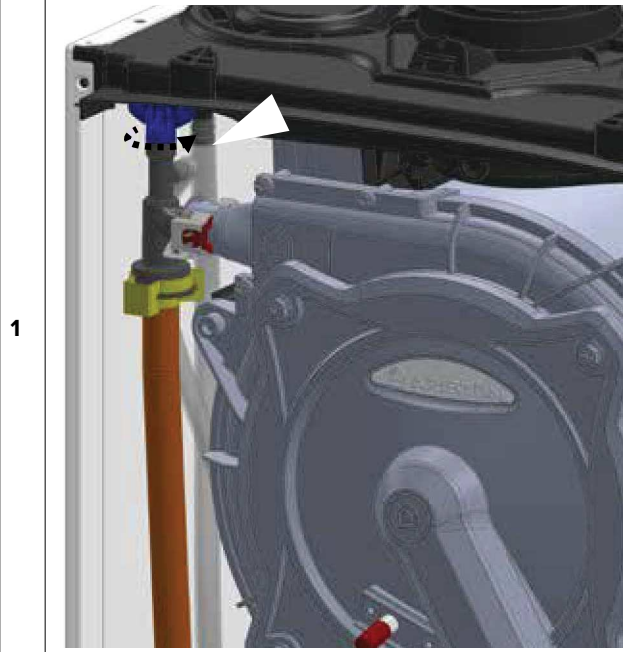
Drain boiler (see 3.3)  
Unscrew and lift the manual air vent from the exchanger

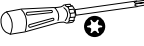

**3.17 Main heat exchanger**

Tools   

TIME  20 min

Drain boiler (see 3.3)  
Remove the silencer

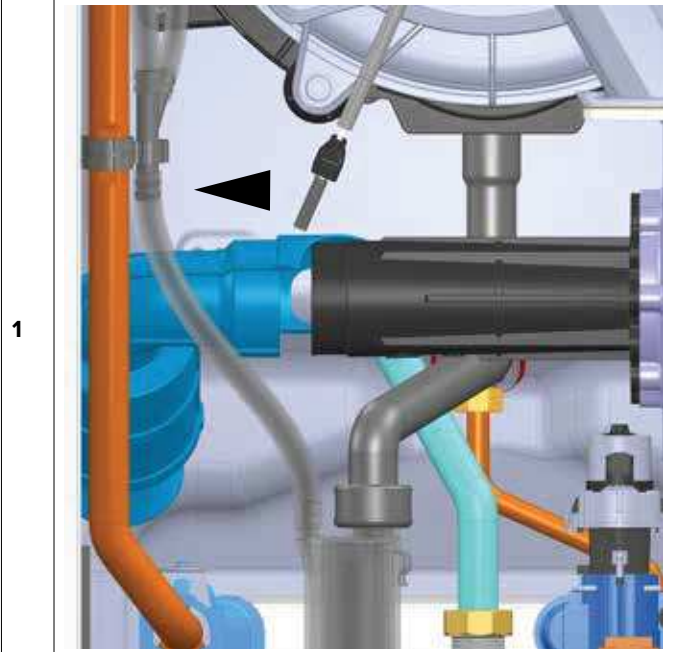

Isolate the gas supply and disconnect the gas pipe.

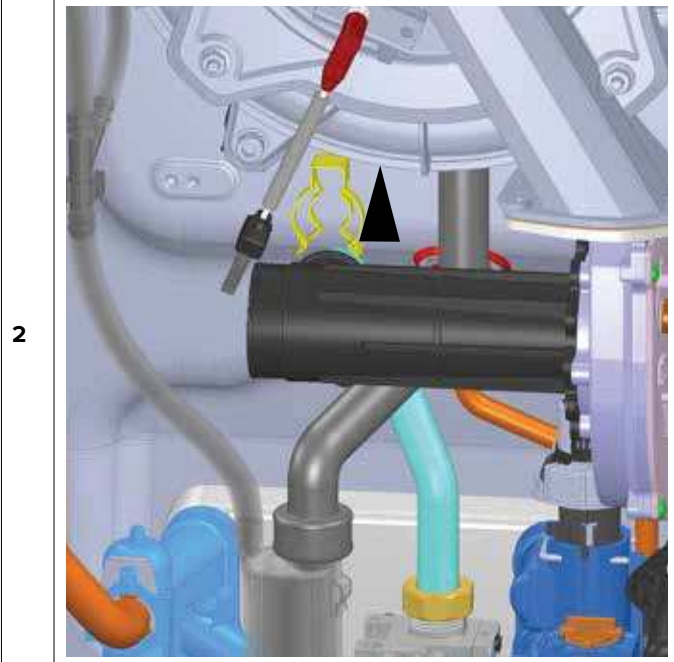

Disconnect the cable of the electrode.  
Remove the four nuts and remove the burner unit

3



4

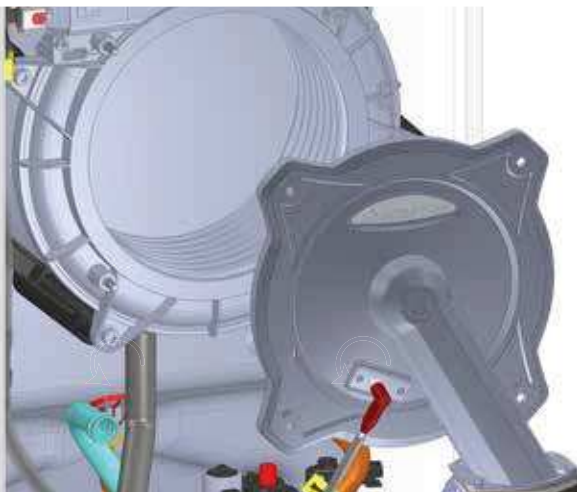

Remove the two clips to disconnect the exchanger on the heating flow side

5

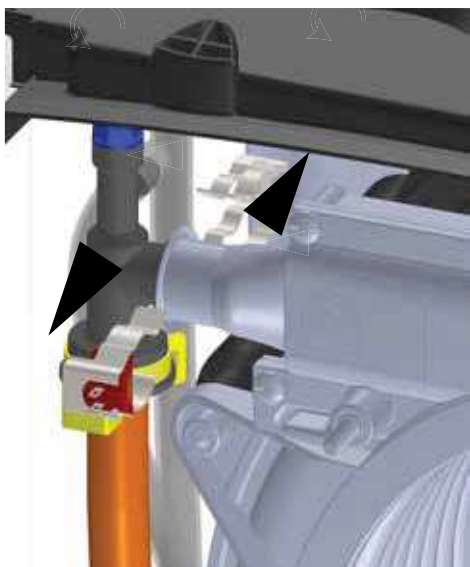

Disconnect the plastic pipes from the manual air vent.

6



Disconnect the heating flow pipe

7



Disconnect the condensate pipe

8



Unscrew the four screws to remove the heat exchanger

9



10



11



## 4. BURNER UNIT

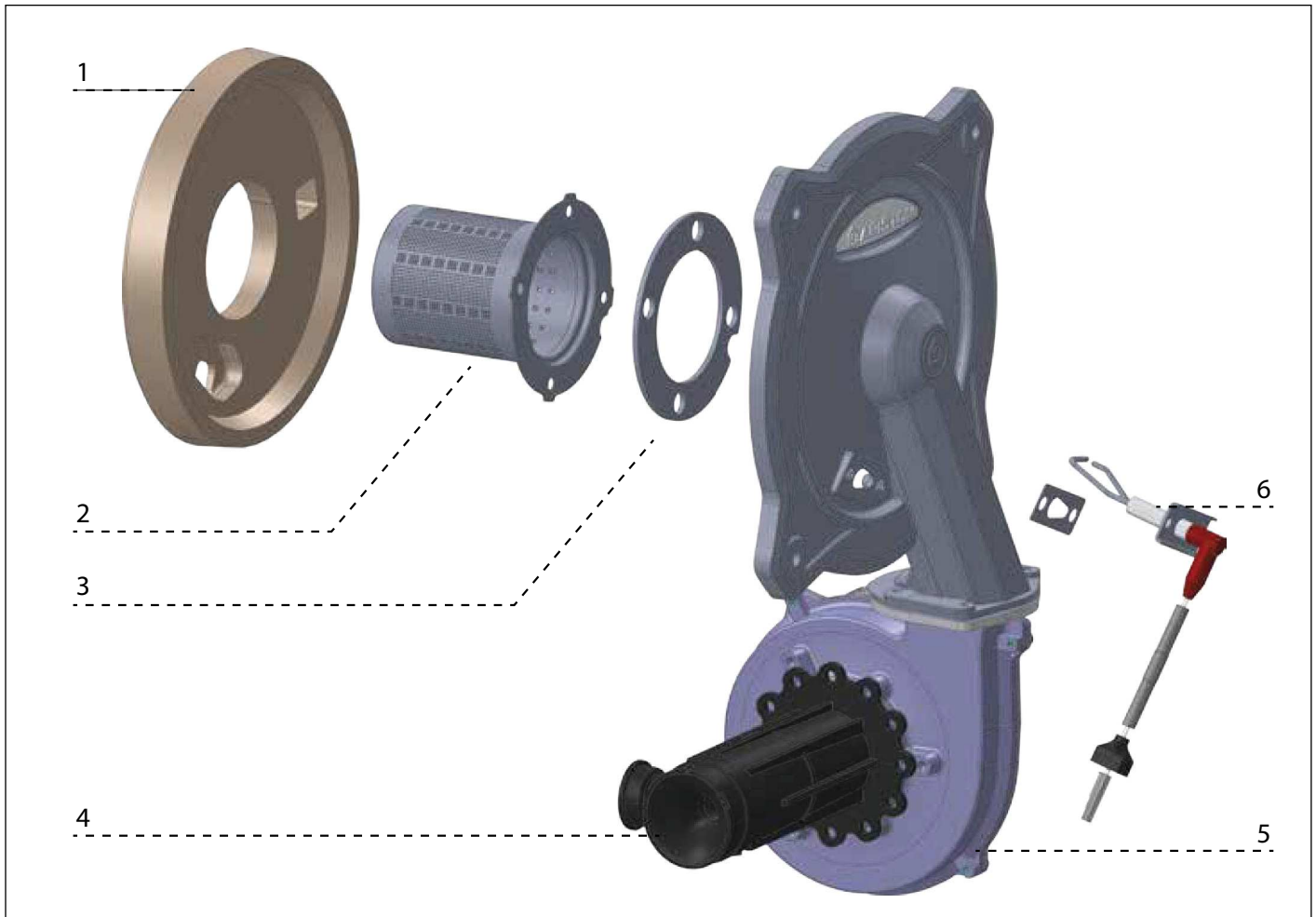

Legend:

- 1 - Ceramic fibre
- 2 - Burner
- 3 - Silencer
- 4 - Mixing tube
- 5 - Fan
- 6 - Detection/Ignition electrode

**4.1 Electrode (detection and ignition)**

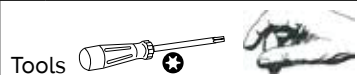

TIME  5 min

Unplug the electrode on the control box  
Remove the screws and pull the electrodes towards you.

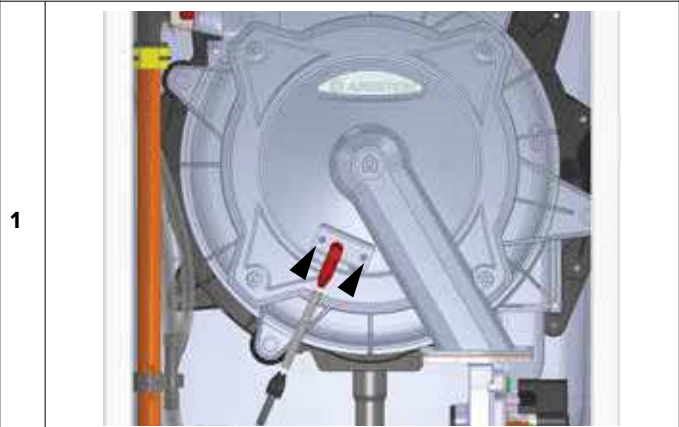

**4.2 Burner**



TIME  15 min

Remove the silencer

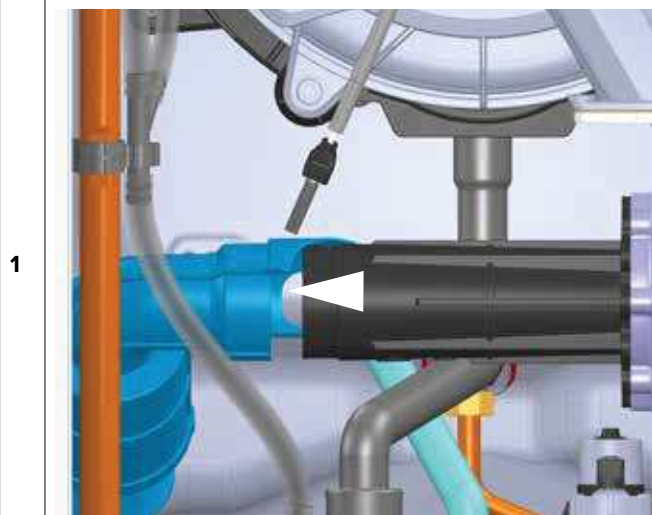

Isolate the gas supply. Disconnect the gas pipe.

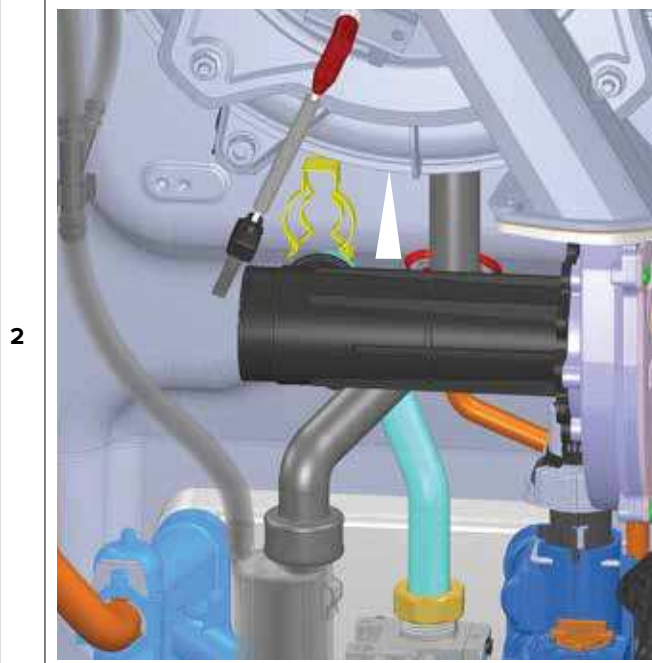

Pull the assembly towards you

3

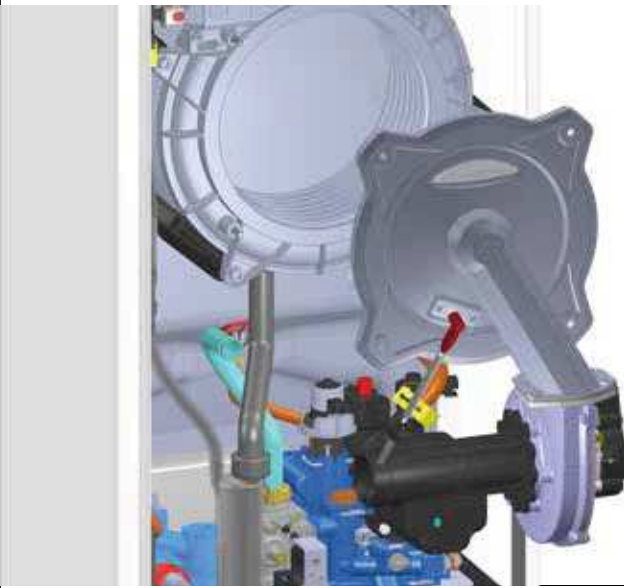

Remove the two screws and remove the electrode

4

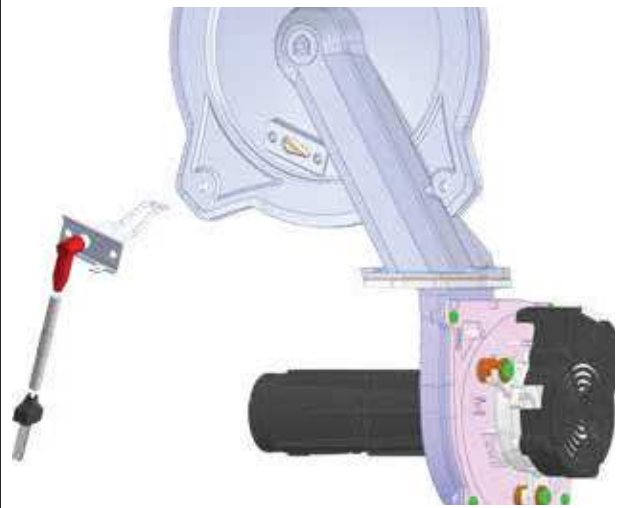

5

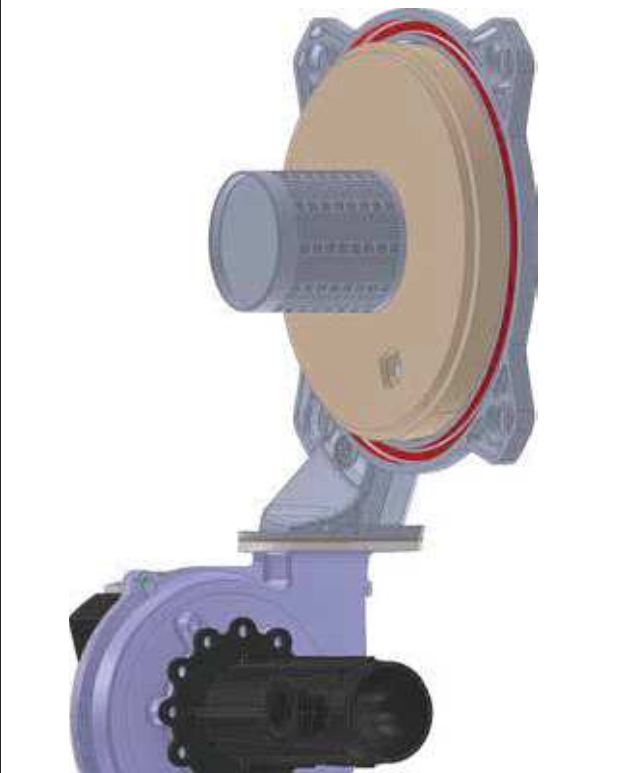

Remove the ceramic fibre.

Remove the four screws and pull the burner toward you.  
**Always replace the burner gasket (\*).**

6

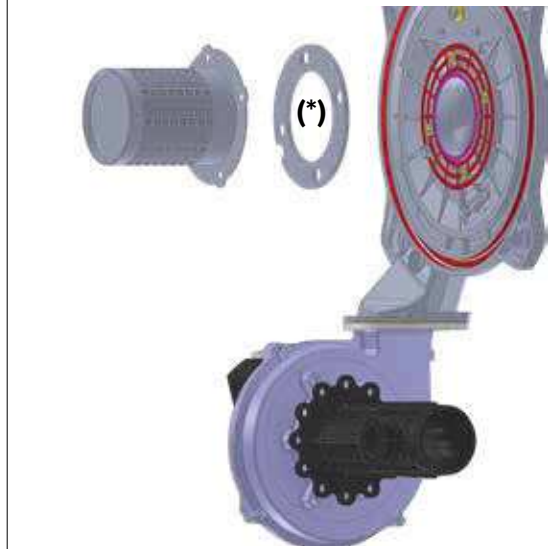

**Verify and replace the other gaskets** if they are damaged or showing signs of deterioration

#### 4.3 Fan

Tools 

TIME  15 min

Remove the silencer (see 4.3 - 1)  
Isolate the gas supply.  
Disconnect the gas pipe (see 4.3 - 2)

1



Remove the three screws to free the fan.

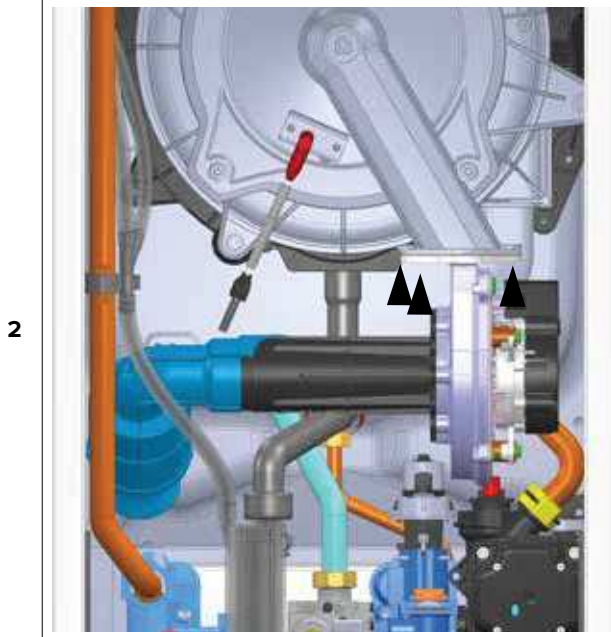

Remove the three nuts.

**Verify and replace the gasket** if it's damaged or showing signs of deterioration



Legend:  
1 - Fan  
2 - Venturi  
3 - Gasket

#### 4.4 Gas Valve

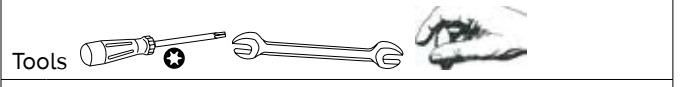

TIME 15 min

Remove the two screws under the boiler and disconnect the gas pipe on the top of the gas valve

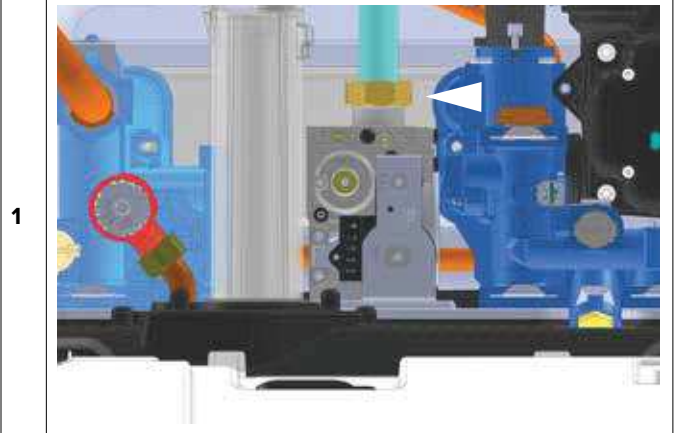

Remove the gas valve

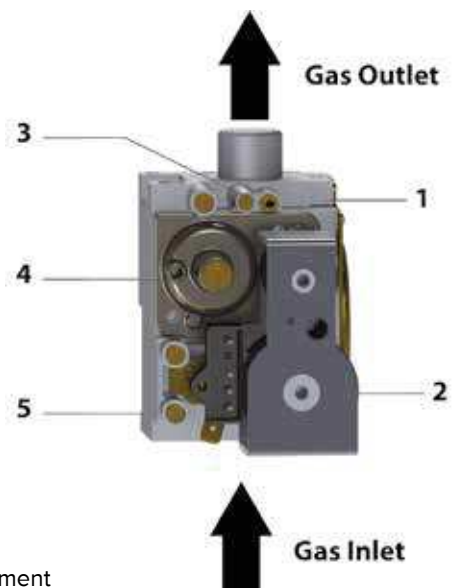
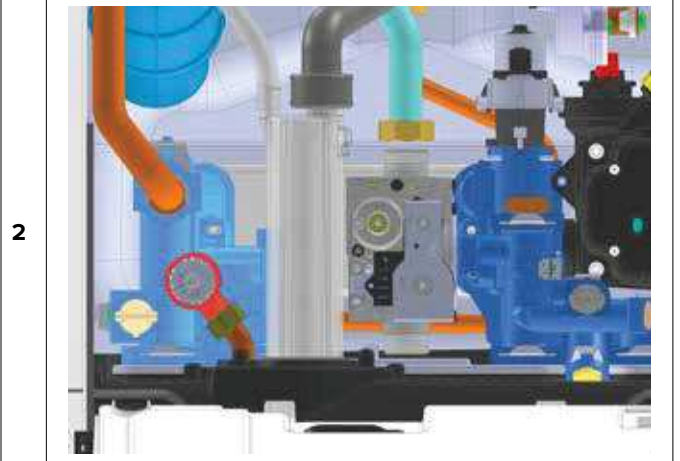





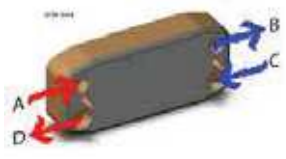

Legend:  
1 - Gas valve  
2 - Solenoids  
3 - Throttle adjustment  
4 - Offset adjustment  
5 - Inlet test nipple

Fan & mixer venturi according to the model

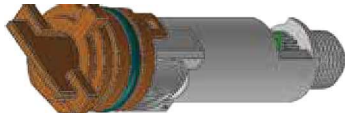
Power	Fan	Venturi diameter
24 kW	EBM 118 85W	Ø 16,1
30 kW	EBM 118 85W	Ø 18,7

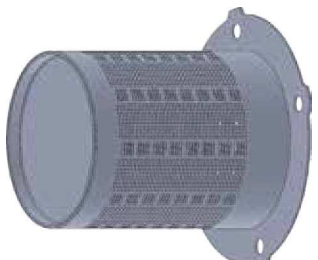
**5. ANNUAL MAINTENANCE**

<p><b>Plate heat exchanger</b>                  Maintenance Interval: As necessary                  How: To measure specification of DHW performance.</p>	
<p><b>By-pass &amp; Safety valve</b>                  Maintenance Interval: Annually                  How: Visual inspection / Clean as necessary</p>	
<p><b>Central heating filter</b>                  Maintenance Interval: Annually                  How: Visual inspection / Clean as necessary</p>	
<p><b>Flow switch operation</b>                  Maintenance Interval: Annually                  How: Visual inspection / Clean as necessary / Check flow rate</p>	
<p><b>Expansion vessel</b>                  Maintenance Interval: Annually                  How: Check air pressure is at 15 psi (System drained)</p>	
<p><b>Ignition &amp; detection electrode</b>                  Maintenance Interval: Annually                  How: Visual inspection / Clean as necessary / Distance from the burner / Ionisation current more than 1 µA</p>	
<p><b>Burner</b>                  Maintenance Interval: Annually                  How: Visual inspection / Clean as necessary</p>	
<p><b>Fan</b>                  Maintenance Interval: Annually                  How : Visual inspection / Clean as necessary</p>	

<p><b>Primary Heat exchanger</b>          Maintenance Interval: Annually          How : Visual inspection / Clean as necessary</p>	
<p><b>Condensate trap</b>          Maintenance Interval: Annually          or after cleaning primary heat exchanger          How : Visual inspection / Clean as necessary /          Add water before replacing</p>	
<p><b>Pump</b>          Maintenance Interval: At the first ignition and annually          How: Check that the AAV is open /          Visual inspection / Clean as necessary</p>	

## TECHNICAL DATA

GENERAL NOTE	Model:		E-COMBI ONE	
			24	30
	CE Certification (pin)			0085CR0393
Boiler type			C13(X)-C23-C33(X)-C43(X)-C53(X)-C63(X)C83(X)-C93(X) B23-B23P-B33	
POWER SPECIFICATIONS	Max/min nominal calorific flow rate (Hi) Qn	kW	22,0 / 3,7	28,0 / 4,3
	Max/min nominal calorific flow rate (Hs) Qn	kW	24,4 / 4,1	31,1 / 4,8
	Domestic hot water max/min nominal calorific flow rate (Hi) Qn	kW	26,0 / 3,7	30,0 / 4,3
	Domestic hot water max/min nominal calorific flow rate (Hs) Qn	kW	28,9 / 4,1	33,3 / 4,8
	Max/min power output (80°C-60°C) Pn	kW	21,4 / 3,4	27,4 / 3,9
	Max/min power output (50°C-30°C) Pn	kW	23,6 / 3,9	30 / 4,5
	Domestic hot water max/min power output Pn	kW	24,9 / 3,5	28,7 / 4,1
	Combustion efficiency (of flue gas)	%	98,0	98,0
	Nominal calorific flow rate efficiency (60/80°C) (Hi)	%	97,5 / 87,8	97,9 / 88,2
	Nominal calorific flow rate efficiency (30/50°C) (Hi)	%	107,3 / 96,7	107,3 / 96,6
	Efficiency at 30% at 30°C	%	109,8 / 98,9	109,6 / 98,7
	Minimum calorific flow rate efficiency (60/80°C) (Hi)	%	93,1 / 83,8	91,1 / 82
	Efficiency rating (dir. 92/42/EEC)	stars	★★★★	
	Sedbuk class		A/90	A/90
	Loss of burner gas when operating	%	2,0	2,0
EMISSIONS	Available air pressure	Pa	100	100
	NoX class	class	6	
	Flue gas temperature (G20) (80°C-60°C)	°C	61	62
	CO2 content (G20) (80°C-60°C) max / min	%	9,2 / 8,9	
	CO content (0%O2) (80°C-60°C)	ppm	141,8	123,8
	O2 content (G20) (80°C-60°C)	%	3,9	4,2
	Maximum flue gas flow (G20) (80°C-60°C)	Kg/h	42,1	48,6
	Excess air (80°C-60°C)	%	23	25
HEATING CIRCUIT	Expansion chamber inflation pressure	bar	1	
	Maximum heating pressure	bar	3	
	Expansion chamber capacity	l	8	
	Min/max heating temperature (high temperature range)	°C	35 / 82	
	Min/max heating temperature (low temperature range)	°C	20 / 45	
DOMESTIC HOT WATER CIRCUIT	Domestic hot water min/max temperature	°C	36 / 60	
	Specific flow rate of domestic hot water (ΔT=30°C)	l/min	12,1	14,5
	Quantity of hot water ΔT=25°C	l/min	14,5	17,4
	Quantity of hot water ΔT=35°C	l/min	10,4	12,5
	Hot water comfort rating (EN13203)	stars	★★★	
	Hot water minimum flow rate	l/min	2,0	2,0
	Domestic hot water max/min pressure	bar	7 / 0,2	
ELECTRICAL	Power supply frequency/voltage	V/Hz	230 / 50	
	Total electrical power absorbed	W	77	83
	Minimum ambient temperature for use	°C	+5	
	Protection level for the electrical appliance	IP	X5D	
	Weight	kg	29,7	32,3





GENERAL NOTE	Model:		E-SYSTEM ONE	
			24	30
CE Certification (pin)			0085CR0393	
Boiler type			C13(X)-C23-C33(X)-C43(X)-C53(X)-C63(X)C83(X)-C93(X) B23-B23P-B33	
POWER SPECIFICATIONS	Max/min nominal calorific flow rate (Hi) Qn	kW	22,0 / 3,7	28,0 / 4,3
	Max/min nominal calorific flow rate (Hs) Qn	kW	24,4 / 4,1	31,1 / 4,8
	Domestic hot water max/min nominal calorific flow rate (Hi) Qn	kW	26,0 / 3,7	30,0 / 4,3
	Domestic hot water max/min nominal calorific flow rate (Hs) Qn	kW	28,9 / 4,1	33,3 / 4,8
	Max/min power output (80°C-60°C) Pn	kW	21,4 / 3,4	27,4 / 3,9
	Max/min power output (50°C-30°C) Pn	kW	23,6 / 3,9	30 / 4,5
	Domestic hot water max/min power output Pn	kW	24,9 / 3,5	28,7 / 4,1
	Combustion efficiency (of flue gas)	%	98,0	98,0
	Nominal calorific flow rate efficiency (60/80°C) (Hi)	%	97,5 / 87,8	97,9 / 88,2
	Nominal calorific flow rate efficiency (30/50°C) (Hi)	%	107,3 / 96,7	107,3 / 96,6
	Efficiency at 30% at 30°C	%	109,8 / 98,9	109,6 / 98,7
	Minimum calorific flow rate efficiency (60/80°C) (Hi)	%	93,1 / 83,8	91,1 / 82
	Efficiency rating (dir. 92/42/EEC)	stars	★★★★	
	Sedbuk class		A/90	A/90
	Loss of burner gas when operating	%	2,0	2,0
EMISSIONS	Available air pressure	Pa	100	100
	NoX class	class	6	
	Flue gas temperature (G20) (80°C-60°C)	°C	61	62
	CO2 content (G20) (80°C-60°C) max - min	%	9,2 / 8,9	
	CO content (0%O2) (80°C-60°C)	ppm	141,8	123,8
	O2 content (G20) (80°C-60°C)	%	3,9	4,2
	Maximum flue gas flow (G20) (80°C-60°C)	Kg/h	42,1	48,6
	Excess air (80°C-60°C)	%	23	25
HEATING CIRCUIT	Expansion chamber inflation pressure	bar	1	
	Maximum heating pressure	bar	3	
	Expansion chamber capacity	l	8	
	Min/max heating temperature (high temperature range)	°C	35 / 82	
	Min/max heating temperature (low temperature range)	°C	20 / 45	
DOMESTIC HOT WATER CIRCUIT	Domestic hot water min/max temperature	°C	40 / 60	
ELECTRICAL	Power supply frequency/voltage	V/Hz	230 / 50	
	Total electrical power absorbed	W	77	83
	Minimum ambient temperature for use	°C	+5	
	Protection level for the electrical appliance	IP	X5D	
	Weight	kg	29,7	32,3

## TECHNICAL DATA

### ErP Data - EU 813/2013

Model: <b>E-COMBI ONE</b>		<b>24</b>	<b>30</b>
Condensing boiler	yes/no	yes	yes
Low-temperature boiler:	yes/no	no	no
B1 boiler	yes/no	no	no
Cogeneration space heater	yes/no	no	no
Combination heater	yes/no	yes	yes
Contact details ( Name and address of the manufacturer or its authorised representative)		ARISTON THERMO S.p.A. Viale A. Merloni 45 60044 FABRIANO AN - ITALIA	
<b>ErP HEATING</b>			
Power output $P_n$	kW	21	27
Useful heat output at rated heat output and high-temperature regime $P_4$	kW	21,4	27,4
Useful heat output at 30 % of rated heat output and low-temperature regime (Return temperature 30°C) $P_1$	kW	6,4	8,2
Seasonal space heating energy efficiency $\eta_s$	%	94	94
Useful efficiency at rated heat output and high-temperature regime (60-80°C) $\eta_4$	%	87,8	88,2
Useful efficiency at 30 % of rated heat output and low-temperature regime (Return temperature 30°C) $\eta_1$	%	98,9	98,7
<b>ErP D.H.W.</b>			
Declared load profile		XL	XL
Water heating energy efficiency $\eta_{WH}$	%	83	82
Daily electricity consumption $Q_{elec}$	kWh	0,200	0,190
Daily fuel consumption $Q_{fuel}$	kWh	23,490	23,870
<b>AUXILIARY ELECTRICITY CONSUMPTION</b>			
At full load $e_{lmax}$	kW	0,030	0,039
At part load $e_{lmin}$	kW	0,014	0,015
In standby mode $P_{SB}$	kW	0,004	0,004
<b>OTHER ITEMS</b>			
Standby heat loss $P_{stby}$	kW	0,039	0,043
Ignition burner power consumption $P_{ign}$	kW	0,000	0,000
Sound power level, indoors $L_{WA}$	dB	49	51
Emissions of nitrogen oxides NOx	mg/kWh	53	46



### PRODUCT FICHE - EU 811/2013

Brand			
Model		<b>E-COMBI ONE</b>	
		<b>24</b>	<b>30</b>
Declared load profile		XL	XL
Seasonal space heating energy efficiency class			
Water heating energy efficiency class			
Power output $P_n$	kW	21	27
Annual energy consumption $Q_{HE}$	GJ	40	50
Annual electricity consumption AEC	kWh	44	42
Annual fuel consumption AFC	GJ	19	19
Seasonal space heating energy efficiency $\eta_s$	%	94	94
Water heating energy efficiency $\eta_{WH}$	%	83	82
Sound power level, indoors $L_{WA}$	dB	49	50

**ErP Data - EU 813/2013**

Model: <b>E-SYSTEM ONE</b>		<b>24</b>	<b>30</b>
Condensing boiler	yes/no	yes	yes
Low-temperature boiler:	yes/no	no	no
B1 boiler	yes/no	no	no
Cogeneration space heater	yes/no	no	no
Combination heater	yes/no	no	no
Contact details (Name and address of the manufacturer or its authorised representative)		ARISTON THERMO S.p.A. Viale A. Merloni 45 60044 FABRIANO AN - ITALIA	
<b>ErP HEATING</b>			
Power output $P_n$	kW	21	27
Useful heat output at rated heat output and high-temperature regime $P_4$	kW	21,4	27,4
Useful heat output at 30 % of rated heat output and low-temperature regime (Return temperature 30°C) $P_1$	kW	6,4	8,2
Seasonal space heating energy efficiency $\eta_s$	%	94	94
Useful efficiency at rated heat output and high-temperature regime (60-80°C) $\eta_4$	%	87,8	88,2
Useful efficiency at 30 % of rated heat output and low-temperature regime (Return temperature 30°C) $\eta_1$	%	98,8	98,7
<b>AUXILIARY ELECTRICITY CONSUMPTION</b>			
At full load $e_{lmax}$	kW	0,030	0,039
At part load $e_{lmin}$	kW	0,014	0,015
In standby mode $P_{SB}$	kW	0,004	0,004
<b>OTHER ITEMS</b>			
Standby heat loss $P_{stby}$	kW	0,039	0,043
Ignition burner power consumption $P_{ign}$	kW	0,000	0,000
Sound power level, indoors $L_{WA}$	dB	49	51
Emissions of nitrogen oxides NOx	mg/kWh	53	46

**PRODUCT FICHE - EU 811/2013**

Brand			
Model	E-SYSTEM ONE		
		<b>24</b>	<b>30</b>
Seasonal space heating energy efficiency class			
Power output $P_n$	kW	21	27
Annual energy consumption $Q_{HE}$	GJ	40	50
Seasonal space heating energy efficiency $\eta_s$	%	94	94
Sound power level, indoors $L_{WA}$	dB	49	51

Package fiche

ENERGY

1
2

3

A

6

+

+

+

+

5

2015
811/2013

**Instructions for filling the label for packages of space heater (or combination heater), temperature control and solar device.**

1. supplier's name or trademark;
2. supplier's model identifier;
3. the seasonal space heating energy efficiency class of the space heater, already filled;
4. the seasonal space heating and water heating energy efficiency classes of the combination heater already filled;
5. Indication of whether a solar collector, hot water storage tank, temperature control and/or supplementary heater, may be included in the package of combination heater, temperature control and solar device;
6. the seasonal space heating energy efficiency class of the package of combination heater, temperature control and solar device, determined in accordance with the figure 1 in the following pages.  
The head of the arrow containing the seasonal space heating energy efficiency class of the package of combination heater, temperature control and solar device shall be placed at the same height as the head of the relevant energy efficiency class;
7. the water heating energy efficiency class of the package of combination heater, temperature control and solar device, determined in accordance with the figure 5 in the following pages.  
The head of the arrow containing the water heating energy efficiency class of the package of combination heater, temperature control and solar device shall be placed at the same height as the head of the relevant energy efficiency class.

ENERGY

1
2

3

4

A

A

XL

7

+

+

+

+

5

2015
811/2013

The energy efficiency of the package of products provided for this fiche may not correspond to its actual energy efficiency once installed in a building, as the efficiency is influenced by further factors such as heat loss in the distribution system and the dimensioning of the products in relation to building size and characteristics.

PACKAGES OF COMBINATION HEATER, TEMPERATURE CONTROL AND SOLAR DEVICE

The fiche for packages of combination heater, temperature control and solar device shall contain the elements set out in points (a) and (b):

a) the elements set out in Figure 1, respectively, for evaluating the seasonal space heating energy efficiency of a package of combination heater, temperature control and solar device, including the following information:

- I: the value of the seasonal space heating energy efficiency of the preferential combination heater, expressed in %;
- II: the factor for weighting the heat output of the preferential and supplementary heaters of a package (see COMMISSION DELEGATED REGULATION (EU) No 811/2013 - annex IV - 6.a);
- III: the value of the mathematical expression:  $294 / (11 \cdot Prated)$ , whereby Prated is related to the preferential combination heater;
- IV: the value of the mathematical expression  $115 / (11 \cdot Prated)$ , whereby Prated is related to the preferential combination heater;

in addition, for preferential heat pump combination heaters:

- V: the value of the difference between the seasonal space heating energy efficiencies under average and colder climate conditions, expressed in %;
- VI: the value of the difference between the seasonal space heating energy efficiencies under warmer and average climate conditions, expressed in %;

(b) the elements set out in Figure 5 for evaluating the water heating energy efficiency of a package of combination heater, temperature control and solar device, where the following information shall be included:

- I: the value of the water heating energy efficiency of the combination heater, expressed in %;
- II: the value of the mathematical expression  $(220 \cdot Q_{ref}) / Q_{nonsol}$ , where  $Q_{ref}$  is taken from Table 15 in Annex VII of the COMMISSION DELEGATED REGULATION (EU) N. 811/2013 and  $Q_{nonsol}$  from the product fiche of the solar device for the declared load profile M, L, XL or XXL of the combination heater;
- III: the value of the mathematical expression  $(Q_{aux} \cdot 2,5) / (220 \cdot Q_{ref})$ , expressed in %, where  $Q_{aux}$  is taken from the product fiche of the solar device and  $Q_{ref}$  from Table 15 in Annex VII of the COMMISSION DELEGATED REGULATION (EU) N. 811/2013 for the declared load profile M, L, XL or XXL.

## TECHNICAL DATA

Figure 1

Seasonal space heating energy efficiency of boiler ①  
 %

---

Temperature control ②  
 From fiche of temperature control +  %

Class  
 I = 1%, II = 2%, III = 1,5%, IV = 2%,  
 V = 3%, VI = 4 %, VII = 3,5%, VIII = 5%

---

Supplementary boiler ③  
 From fiche of boiler ±  %

Seasonal space heating energy efficiency (in %)

(  - '1' ) x 0,1 =

---

Solar contribution - From fiche of solar device

Collector size ( in m<sup>2</sup> )

Tank volume ( in m<sup>3</sup> )

Collector efficiency ( in % )

Tank rating  
 A\* = 0,95, A = 0,91,  
 B = 0,86, C = 0,83, D-G = 0,81

( 'III' x  + 'IV' x  ) x 0,9 x (  /100 ) x  = ④  
+  %

---

Supplementary heat pump ⑤  
 From fiche of heat pump +  %

Seasonal space heating energy efficiency (in %)

(  - '1' ) x 'II'

---

Solar contribution and supplementary heat pump

Select smaller value ⑥  
 0,5 x  OR 0,5 x  = -  %

---

Seasonal space heating energy efficiency of package ⑦  
 %

---

Seasonal space heating energy efficiency class of package

<input type="checkbox"/>	<input type="checkbox"/>	<input type="checkbox"/>	<input type="checkbox"/>	<input type="checkbox"/>	<input type="checkbox"/>	<input type="checkbox"/>	<input type="checkbox"/>	<input type="checkbox"/>	<input type="checkbox"/>
<b>G</b>	<b>F</b>	<b>E</b>	<b>D</b>	<b>C</b>	<b>B</b>	<b>A</b>	<b>A<sup>+</sup></b>	<b>A<sup>++</sup></b>	<b>A<sup>+++</sup></b>
< 30%	≥ 30%	≥ 34%	≥ 36%	≥ 75%	≥ 82%	≥ 90%	≥ 98%	≥ 125%	≥ 150%

---

Boiler and supplementary heat pump installed with low temperature heat emitters at 35 °C?  
 From fiche of heat pump ⑦  
 + (50 x 'II') =  %

The energy efficiency of the package of products provided for this fiche may not correspond to its actual energy efficiency once installed in a building, as the efficiency is influenced by further factors such as heat loss in the distribution system and the dimensioning of the products in relation to building size and characteristics.

Figure 5

Water heating energy efficiency of combination heater

Declared load profile:

<sup>1</sup>  
 %

Solar contribution - From fiche of solar device

Auxiliary electricity

$$(1,1 \times 'I' - 10\%) \times 'II' - 'III' - 'I' = + \text{ \%}$$

<sup>3</sup>  
 %

Water heating energy efficiency of package under average climate

Water heating energy efficiency class of package under average climate

		<input type="checkbox"/>	<input type="checkbox"/>	<input type="checkbox"/>	<input type="checkbox"/>	<input type="checkbox"/>	<input type="checkbox"/>	<input type="checkbox"/>	<input type="checkbox"/>	<input type="checkbox"/>	
		<b>G</b>	<b>F</b>	<b>E</b>	<b>D</b>	<b>C</b>	<b>B</b>	<b>A</b>	<b>A<sup>+</sup></b>	<b>A<sup>++</sup></b>	<b>A<sup>+++</sup></b>
<input type="checkbox"/>	<b>M</b>	< 27 %	≥ 27 %	≥ 30 %	≥ 33 %	≥ 36 %	≥ 39 %	≥ 65 %	≥ 100 %	≥ 130 %	≥ 163 %
<input type="checkbox"/>	<b>L</b>	< 27 %	≥ 27 %	≥ 30 %	≥ 34 %	≥ 37 %	≥ 50 %	≥ 75 %	≥ 115 %	≥ 150 %	≥ 188 %
<input type="checkbox"/>	<b>XL</b>	< 27 %	≥ 27 %	≥ 30 %	≥ 35 %	≥ 38 %	≥ 55 %	≥ 80 %	≥ 125 %	≥ 160 %	≥ 200 %
<input type="checkbox"/>	<b>XXL</b>	< 28 %	≥ 28 %	≥ 32 %	≥ 36 %	≥ 40 %	≥ 60 %	≥ 85 %	≥ 131 %	≥ 170 %	≥ 213 %

Water heating energy efficiency under colder and warmer climate conditions

Colder: <sup>3</sup> - 0,2 x <sup>2</sup> =  %

Warmer: <sup>3</sup> + 0,4 x <sup>2</sup> =  %

The energy efficiency of the package of products provided for this fiche may not correspond to its actual energy efficiency once installed in a building, as the efficiency is influenced by further factors such as heat loss in the distribution system and the dimensioning of the products in relation to building size and characteristics.



# Benchmark Commissioning & Warranty Validation Service Record

It is a requirement that the boiler is installed and commissioned to the manufacturers' instructions and the data fields on the commissioning checklist completed in full.

To instigate the boiler warranty the boiler needs to be registered with the manufacturer within one month of the installation. The warranty rests with the end-user (consumer), and they should be made aware it is ultimately their responsibility to register with the manufacturer, within the allotted time period.

It is essential that the boiler is serviced in line with the manufacturers' recommendations, at least annually. This must be carried out by a competent Gas Safe registered engineer. The service details should be recorded on the Benchmark Service and Interim Boiler Work Record and left with the householder. Failure to comply with the manufacturers' servicing instructions and requirements will invalidate the warranty.



[www.hhic.co.uk](http://www.hhic.co.uk)

**This Commissioning Checklist is to be completed in full by the competent person who commissioned the boiler as a means of demonstrating compliance with the appropriate Building Regulations and then handed to the customer to keep for future reference.**

Failure to install and commission according to the manufacturers' instructions and complete this Benchmark Commissioning Checklist will invalidate the warranty. This does not affect the customer's statutory rights.

\* All installations in England and Wales must be notified to Local Authority Building Control (LABC) either directly or through a Competent Persons Scheme. A Building Regulations Compliance Certificate will then be issued to the customer.

© Heating and Hotwater Industry Council (HHIC)



[www.benchmark.org.uk](http://www.benchmark.org.uk)

## GAS BOILER SYSTEM COMMISSIONING CHECKLIST & WARRANTY VALIDATION RECORD

Address:															
Boiler make and model:															
Boiler serial number:															
Commissioned by (PRINT NAME):						Gas Safe registration number:									
Company name:						Telephone number:									
Company email:						Company address:									
										Commissioning date:					
Heating and hot water system complies with the appropriate Building Regulations?											Yes				
Optional: Building Regulations Notification Number (if applicable):															
Time, temperature control and boiler interlock provided for central heating and hot water											Yes				
Boiler Plus requirements (tick the appropriate box(s))															
Boiler Plus option chosen for combination boiler in ENGLAND						Weather compensation			Smart thermostat with automisation and optimisation						
						Load compensation			Flue Gas Heat Recovery						
Time and temperature control to hot water		Cylinder thermostat and programmer/timer						Combination boiler							
Zone valves		pre-existing		Fitted		Not required									
Thermostatic radiator valves		pre-existing		Fitted		Not required									
Automatic bypass to system		pre-existing		Fitted		Not required									
Underfloor heating		pre-existing		Fitted		Not required									
Water quality															
The system has been flushed, cleaned and a suitable inhibitor applied upon final fill, in accordance with BS7593 and boiler manufacturers' instructions											Yes				
What system cleaner was used?						Brand:			Product:						
What inhibitor was used?						Brand:			Product:						
Primary water system filter		pre-existing		Fitted		Not required									
CENTRAL HEATING MODE measure and record (as appropriate)															
Gas rate (for combination boilers complete DHW mode gas rate)						m <sup>3</sup> /hr		or		ft <sup>3</sup> /hr					
Central heating output left at factory settings?						Yes		No							
If no, what is the maximum central heating output selected?						kW									
Dynamic gas inlet pressure						mbar									
Central heating flow temperature						°C									
Central heating return temperature						°C									
System correctly balanced/rebalanced?						Yes									
COMBINATION BOILERS ONLY															
Is the installation in a hard water area (above 200ppm)?						Yes		No							
Water scale reducer/softener		pre-existing		Fitted		Not required									
What type of scale reducer/softener has been fitted?						Brand:			Product:						
Water meter fitted?						Yes		No							
If yes- DHW expansion vessel		pre-existing		Fitted		Not required									
Pressure reducing valve		pre-existing		Fitted		Not required									
DOMESTIC HOT WATER MODE Measure and record															
Gas rate						m <sup>3</sup> /hr		or		ft <sup>3</sup> /hr					
Dynamic gas inlet pressure at maximum rate						mbar									
Cold water inlet temperature						°C									
Hot water has been checked at all outlets						Yes		Temperature		°C					
CONDENSATE DISPOSAL															
The condensate drain has been installed in accordance with the manufacturers' instructions and/or BS5546/BS6798											Yes				
Point of termination						Internal		External (only where internal termination impractical)							
Method of disposal						Gravity		Pumped							
ALL INSTALLATIONS															
Record the following		At max rate:		CO		ppm		CO <sub>2</sub>		%		CO/CO <sub>2</sub>		Ratio	
		At min rate (where possible)		CO		ppm		CO <sub>2</sub>		%		CO/CO <sub>2</sub>		Ratio	
Where possible, has a flue integrity check been undertaken in accordance with manufacturers' instructions, and readings are correct?											Yes				
The operation of the boiler and system controls have been demonstrated to and understood by the customer											Yes				
The manufacturers' literature, including Benchmark Checklist and Service Record, has been explained and left with the customer											Yes				
Commissioning Engineer's signature															
Customer's signature (To confirm satisfactory demonstration and receipt of manufacturers' literature)															

\* All installations in England and Wales must be notified to Local Authority Building Control (LABC) either directly or through a Competent Persons Scheme. A Building Regulations Compliance Certificate will then be issued to the customer.

© Heating and Hotwater Industry Council (HHIC)



www.benchmark.org.uk

# SERVICE & INTERIM BOILER WORK RECORD

It is recommended that your boiler and heating system are regularly serviced and maintained, in line with manufacturers' instructions, and that the appropriate service / interim work record is completed.

## Service provider

When completing a service record (as below), please ensure you have carried out the service as described in the manufacturers' instructions. Always use the manufacturers' specified spare parts.

SERVICE/INTERIM WORK ON BOILER <small>delete as appropriate</small>				Date:
Engineer name:		Company name:		
Telephone N°:		Gas Safe registration N°:		
Max rate	CO	ppm	CO <sub>2</sub>	% CO/CO <sub>2</sub>
Min rate	CO	ppm	CO <sub>2</sub>	% CO/CO <sub>2</sub>
Where possible, has a flue integrity check been undertaken in accordance with manufacturers' instructions, and readings are correct?"				yes
Gas rate:	m <sup>3</sup> /h	OR	ft <sup>3</sup> /h	
Were parts fitted? <small>delete as appropriate</small>		Yes	No	
Parts fitted:				
System inhibitor concentration has been checked and appropriate action taken, in accordance with BS 7593 and boiler manufacturers' instructions. *			yes	n/a
Comments:				
Signature:				

\*A System inhibitor efficacy test is required on every annual service in accordance with the manufacturers' instructions and BS 7593. It is only acceptable to not have undertaken this if the service engineers attendance visit was in between annual services to attend a non-water facing component.

SERVICE/INTERIM WORK ON BOILER <small>delete as appropriate</small>				Date:
Engineer name:		Company name:		
Telephone N°:		Gas Safe registration N°:		
Max rate	CO	ppm	CO <sub>2</sub>	% CO/CO <sub>2</sub>
Min rate	CO	ppm	CO <sub>2</sub>	% CO/CO <sub>2</sub>
Where possible, has a flue integrity check been undertaken in accordance with manufacturers' instructions, and readings are correct?"				yes
Gas rate:	m <sup>3</sup> /h	OR	ft <sup>3</sup> /h	
Were parts fitted? <small>delete as appropriate</small>		Yes	No	
Parts fitted:				
System inhibitor concentration has been checked and appropriate action taken, in accordance with BS 7593 and boiler manufacturers' instructions. *			yes	n/a
Comments:				
Signature:				

\*A System inhibitor efficacy test is required on every annual service in accordance with the manufacturers' instructions and BS 7593. It is only acceptable to not have undertaken this if the service engineers attendance visit was in between annual services to attend a non-water facing component.

SERVICE/INTERIM WORK ON BOILER <small>delete as appropriate</small>				Date:
Engineer name:		Company name:		
Telephone N°:		Gas Safe registration N°:		
Max rate	CO	ppm	CO <sub>2</sub>	% CO/CO <sub>2</sub>
Min rate	CO	ppm	CO <sub>2</sub>	% CO/CO <sub>2</sub>
Where possible, has a flue integrity check been undertaken in accordance with manufacturers' instructions, and readings are correct?"				yes
Gas rate:	m <sup>3</sup> /h	OR	ft <sup>3</sup> /h	
Were parts fitted? <small>delete as appropriate</small>		Yes	No	
Parts fitted:				
System inhibitor concentration has been checked and appropriate action taken, in accordance with BS 7593 and boiler manufacturers' instructions. *			yes	n/a
Comments:				
Signature:				

\*A System inhibitor efficacy test is required on every annual service in accordance with the manufacturers' instructions and BS 7593. It is only acceptable to not have undertaken this if the service engineers attendance visit was in between annual services to attend a non-water facing component.

SERVICE/INTERIM WORK ON BOILER <small>delete as appropriate</small>				Date:
Engineer name:		Company name:		
Telephone N°:		Gas Safe registration N°:		
Max rate	CO	ppm	CO <sub>2</sub>	% CO/CO <sub>2</sub>
Min rate	CO	ppm	CO <sub>2</sub>	% CO/CO <sub>2</sub>
Where possible, has a flue integrity check been undertaken in accordance with manufacturers' instructions, and readings are correct?"				yes
Gas rate:	m <sup>3</sup> /h	OR	ft <sup>3</sup> /h	
Were parts fitted? <small>delete as appropriate</small>		Yes	No	
Parts fitted:				
System inhibitor concentration has been checked and appropriate action taken, in accordance with BS 7593 and boiler manufacturers' instructions. *			yes	n/a
Comments:				
Signature:				

\*A System inhibitor efficacy test is required on every annual service in accordance with the manufacturers' instructions and BS 7593. It is only acceptable to not have undertaken this if the service engineers attendance visit was in between annual services to attend a non-water facing component.

SERVICE/INTERIM WORK ON BOILER <small>delete as appropriate</small>				Date:
Engineer name:		Company name:		
Telephone N°:		Gas Safe registration N°:		
Max rate	CO	ppm	CO <sub>2</sub>	% CO/CO <sub>2</sub>
Min rate	CO	ppm	CO <sub>2</sub>	% CO/CO <sub>2</sub>
Where possible, has a flue integrity check been undertaken in accordance with manufacturers' instructions, and readings are correct?"				yes
Gas rate:	m <sup>3</sup> /h	OR	ft <sup>3</sup> /h	
Were parts fitted? <small>delete as appropriate</small>		Yes	No	
Parts fitted:				
System inhibitor concentration has been checked and appropriate action taken, in accordance with BS 7593 and boiler manufacturers' instructions. *			yes	n/a
Comments:				
Signature:				

\*A System inhibitor efficacy test is required on every annual service in accordance with the manufacturers' instructions and BS 7593. It is only acceptable to not have undertaken this if the service engineers attendance visit was in between annual services to attend a non-water facing component.

SERVICE/INTERIM WORK ON BOILER <small>delete as appropriate</small>				Date:
Engineer name:		Company name:		
Telephone N°:		Gas Safe registration N°:		
Max rate	CO	ppm	CO <sub>2</sub>	% CO/CO <sub>2</sub>
Min rate	CO	ppm	CO <sub>2</sub>	% CO/CO <sub>2</sub>
Where possible, has a flue integrity check been undertaken in accordance with manufacturers' instructions, and readings are correct?"				yes
Gas rate:	m <sup>3</sup> /h	OR	ft <sup>3</sup> /h	
Were parts fitted? <small>delete as appropriate</small>		Yes	No	
Parts fitted:				
System inhibitor concentration has been checked and appropriate action taken, in accordance with BS 7593 and boiler manufacturers' instructions. *			yes	n/a
Comments:				
Signature:				

\*A System inhibitor efficacy test is required on every annual service in accordance with the manufacturers' instructions and BS 7593. It is only acceptable to not have undertaken this if the service engineers attendance visit was in between annual services to attend a non-water facing component.

\* All installations in England and Wales must be notified to Local Authority Building Control (LABC) either directly or through a Competent Persons Scheme. A Building Regulations Compliance Certificate will then be issued to the customer.

© Heating and Hotwater Industry Council (HHIC)



www.benchmark.org.uk

# SERVICE & INTERIM BOILER WORK RECORD

It is recommended that your boiler and heating system are regularly serviced and maintained, in line with manufacturers' instructions, and that the appropriate service / interim work record is completed.

## Service provider

When completing a service record (as below), please ensure you have carried out the service as described in the manufacturers' instructions. Always use the manufacturers specified spare parts.

SERVICE/INTERIM WORK ON BOILER <small>delete as appropriate</small>					Date:
Engineer name:		Company name:			
Telephone N°:		Gas Safe registration N°:			
Max rate	CO	ppm	CO <sub>2</sub>	%	CO/CO <sub>2</sub>
Min rate	CO	ppm	CO <sub>2</sub>	%	CO/CO <sub>2</sub>
Where possible, has a flue integrity check been undertaken in accordance with manufacturers' instructions, and readings are correct?"					yes
Gas rate:	m <sup>3</sup> /h	OR	ft <sup>3</sup> /h		
Were parts fitted? <small>delete as appropriate</small>		Yes	No		
Parts fitted:					
System inhibitor concentration has been checked and appropriate action taken, in accordance with BS 7593 and boiler manufacturers' instructions. *					yes
					n/a
Comments:					
Signature:					

\*A System inhibitor efficacy test is required on every annual service in accordance with the manufacturers' instructions and BS 7593. It is only acceptable to not have undertaken this if the service engineers attendance visit was in between annual services to attend a non-water facing component.

SERVICE/INTERIM WORK ON BOILER <small>delete as appropriate</small>					Date:
Engineer name:		Company name:			
Telephone N°:		Gas Safe registration N°:			
Max rate	CO	ppm	CO <sub>2</sub>	%	CO/CO <sub>2</sub>
Min rate	CO	ppm	CO <sub>2</sub>	%	CO/CO <sub>2</sub>
Where possible, has a flue integrity check been undertaken in accordance with manufacturers' instructions, and readings are correct?"					yes
Gas rate:	m <sup>3</sup> /h	OR	ft <sup>3</sup> /h		
Were parts fitted? <small>delete as appropriate</small>		Yes	No		
Parts fitted:					
System inhibitor concentration has been checked and appropriate action taken, in accordance with BS 7593 and boiler manufacturers' instructions. *					yes
					n/a
Comments:					
Signature:					

\*A System inhibitor efficacy test is required on every annual service in accordance with the manufacturers' instructions and BS 7593. It is only acceptable to not have undertaken this if the service engineers attendance visit was in between annual services to attend a non-water facing component.

SERVICE/INTERIM WORK ON BOILER <small>delete as appropriate</small>					Date:
Engineer name:		Company name:			
Telephone N°:		Gas Safe registration N°:			
Max rate	CO	ppm	CO <sub>2</sub>	%	CO/CO <sub>2</sub>
Min rate	CO	ppm	CO <sub>2</sub>	%	CO/CO <sub>2</sub>
Where possible, has a flue integrity check been undertaken in accordance with manufacturers' instructions, and readings are correct?"					yes
Gas rate:	m <sup>3</sup> /h	OR	ft <sup>3</sup> /h		
Were parts fitted? <small>delete as appropriate</small>		Yes	No		
Parts fitted:					
System inhibitor concentration has been checked and appropriate action taken, in accordance with BS 7593 and boiler manufacturers' instructions. *					yes
					n/a
Comments:					
Signature:					

\*A System inhibitor efficacy test is required on every annual service in accordance with the manufacturers' instructions and BS 7593. It is only acceptable to not have undertaken this if the service engineers attendance visit was in between annual services to attend a non-water facing component.

SERVICE/INTERIM WORK ON BOILER <small>delete as appropriate</small>					Date:
Engineer name:		Company name:			
Telephone N°:		Gas Safe registration N°:			
Max rate	CO	ppm	CO <sub>2</sub>	%	CO/CO <sub>2</sub>
Min rate	CO	ppm	CO <sub>2</sub>	%	CO/CO <sub>2</sub>
Where possible, has a flue integrity check been undertaken in accordance with manufacturers' instructions, and readings are correct?"					yes
Gas rate:	m <sup>3</sup> /h	OR	ft <sup>3</sup> /h		
Were parts fitted? <small>delete as appropriate</small>		Yes	No		
Parts fitted:					
System inhibitor concentration has been checked and appropriate action taken, in accordance with BS 7593 and boiler manufacturers' instructions. *					yes
					n/a
Comments:					
Signature:					

\*A System inhibitor efficacy test is required on every annual service in accordance with the manufacturers' instructions and BS 7593. It is only acceptable to not have undertaken this if the service engineers attendance visit was in between annual services to attend a non-water facing component.

SERVICE/INTERIM WORK ON BOILER <small>delete as appropriate</small>					Date:
Engineer name:		Company name:			
Telephone N°:		Gas Safe registration N°:			
Max rate	CO	ppm	CO <sub>2</sub>	%	CO/CO <sub>2</sub>
Min rate	CO	ppm	CO <sub>2</sub>	%	CO/CO <sub>2</sub>
Where possible, has a flue integrity check been undertaken in accordance with manufacturers' instructions, and readings are correct?"					yes
Gas rate:	m <sup>3</sup> /h	OR	ft <sup>3</sup> /h		
Were parts fitted? <small>delete as appropriate</small>		Yes	No		
Parts fitted:					
System inhibitor concentration has been checked and appropriate action taken, in accordance with BS 7593 and boiler manufacturers' instructions. *					yes
					n/a
Comments:					
Signature:					

\*A System inhibitor efficacy test is required on every annual service in accordance with the manufacturers' instructions and BS 7593. It is only acceptable to not have undertaken this if the service engineers attendance visit was in between annual services to attend a non-water facing component.

SERVICE/INTERIM WORK ON BOILER <small>delete as appropriate</small>					Date:
Engineer name:		Company name:			
Telephone N°:		Gas Safe registration N°:			
Max rate	CO	ppm	CO <sub>2</sub>	%	CO/CO <sub>2</sub>
Min rate	CO	ppm	CO <sub>2</sub>	%	CO/CO <sub>2</sub>
Where possible, has a flue integrity check been undertaken in accordance with manufacturers' instructions, and readings are correct?"					yes
Gas rate:	m <sup>3</sup> /h	OR	ft <sup>3</sup> /h		
Were parts fitted? <small>delete as appropriate</small>		Yes	No		
Parts fitted:					
System inhibitor concentration has been checked and appropriate action taken, in accordance with BS 7593 and boiler manufacturers' instructions. *					yes
					n/a
Comments:					
Signature:					

\*A System inhibitor efficacy test is required on every annual service in accordance with the manufacturers' instructions and BS 7593. It is only acceptable to not have undertaken this if the service engineers attendance visit was in between annual services to attend a non-water facing component.

\* All installations in England and Wales must be notified to Local Authority Building Control (LABC) either directly or through a Competent Persons Scheme. A Building Regulations Compliance Certificate will then be issued to the customer.

© Heating and Hotwater Industry Council (HHIC)



www.benchmark.org.uk





ITALIAN DESIGN

Manufactured by

**Ariston Thermo S.p.A.**

Viale Aristide Merloni 45  
60044 Fabriano (AN)  
ITALY

[ariston.com](http://ariston.com)

Imported by

**Ariston Thermo UK Ltd**

3 Juniper West  
Basildon  
SS15 6SJ  
UK

[ariston.com/uk](http://ariston.com/uk)

Customer Service: 0333 240 8777

42001124702 - Rev. 00 - 1122